

REINING PATTERN 11

Thursday June 25 - All Classes

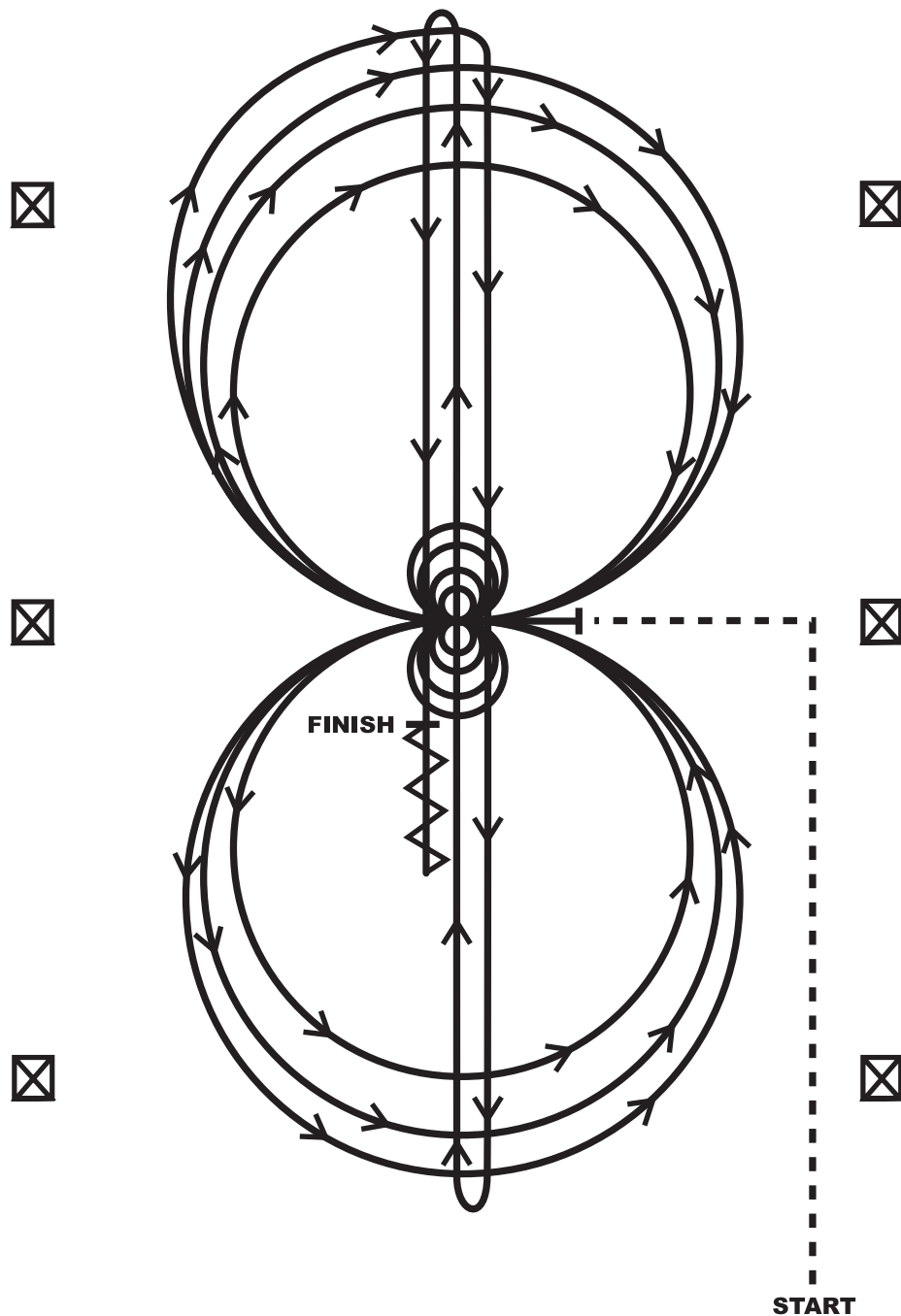

Horses must jog to the center of the arena. Horses must walk or stop prior to starting the pattern. Beginning at the center of the arena facing the left wall or fence.

1. Complete four spins to the left. Hesitate.
2. Complete four spins to the right. Hesitate.
3. Beginning on the right lead complete three circles to the right; the first circle small and slow; the next two circles large and fast. Change leads at the center of the arena.
4. Complete three circles to the left; the first circle small and slow; the next two circles large and fast. Change leads at the center of the arena.
5. Begin a large circle to the right, but do not close this circle. Run down the center of the arena past the end marker and do a right rollback—no hesitation.
6. Run up the middle to the opposite end of the arena past the end marker and do a left rollback—no hesitation.
7. Run past the center marker and do a sliding stop. Back up to the center of the arena or at least ten feet (three meters). Hesitate to demonstrate completion of the pattern.

Ranch Trail

Thurs June 25 - Walk/Trot

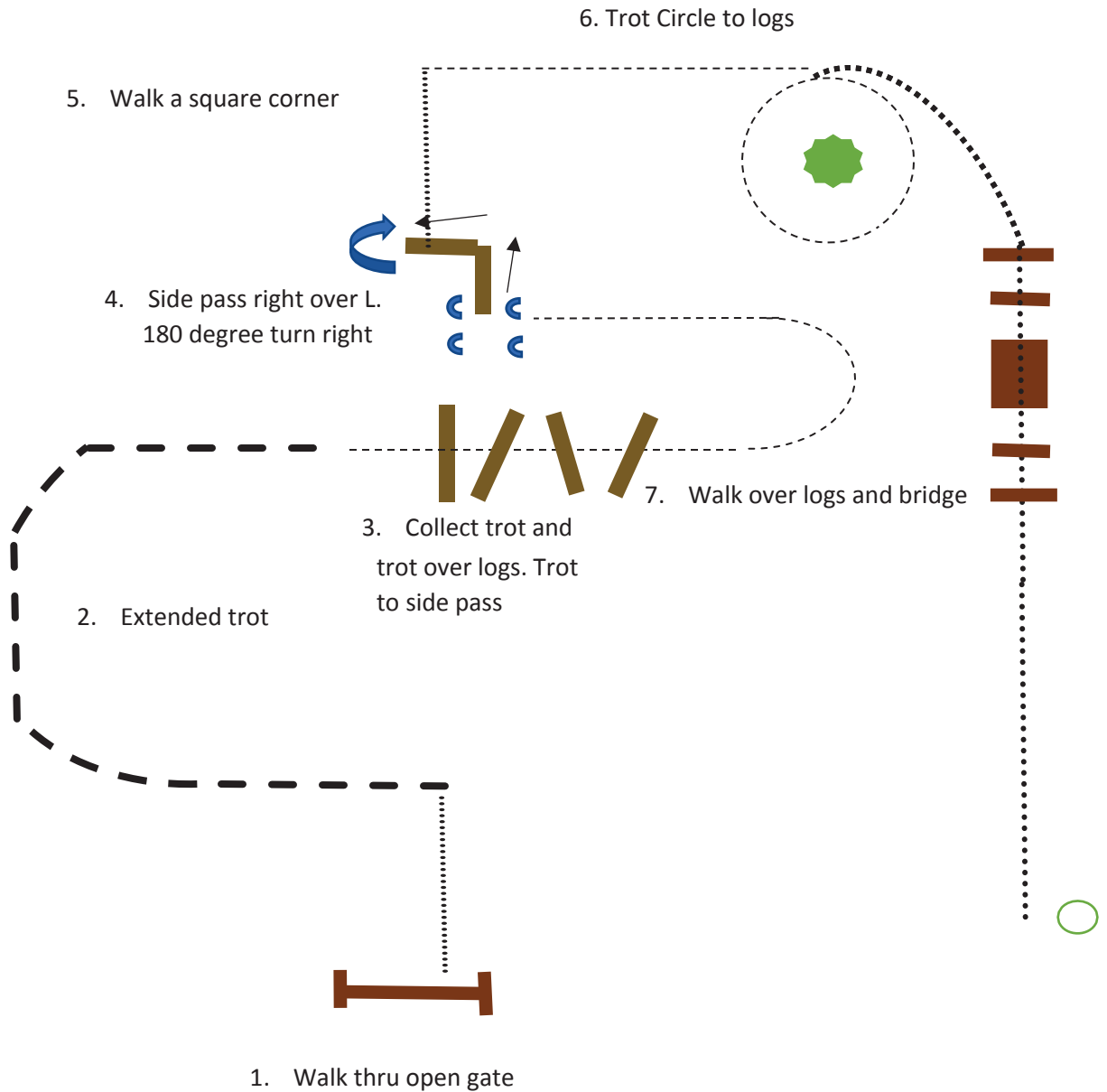

Ranch Trail

Thurs June 25 - Fri June 26

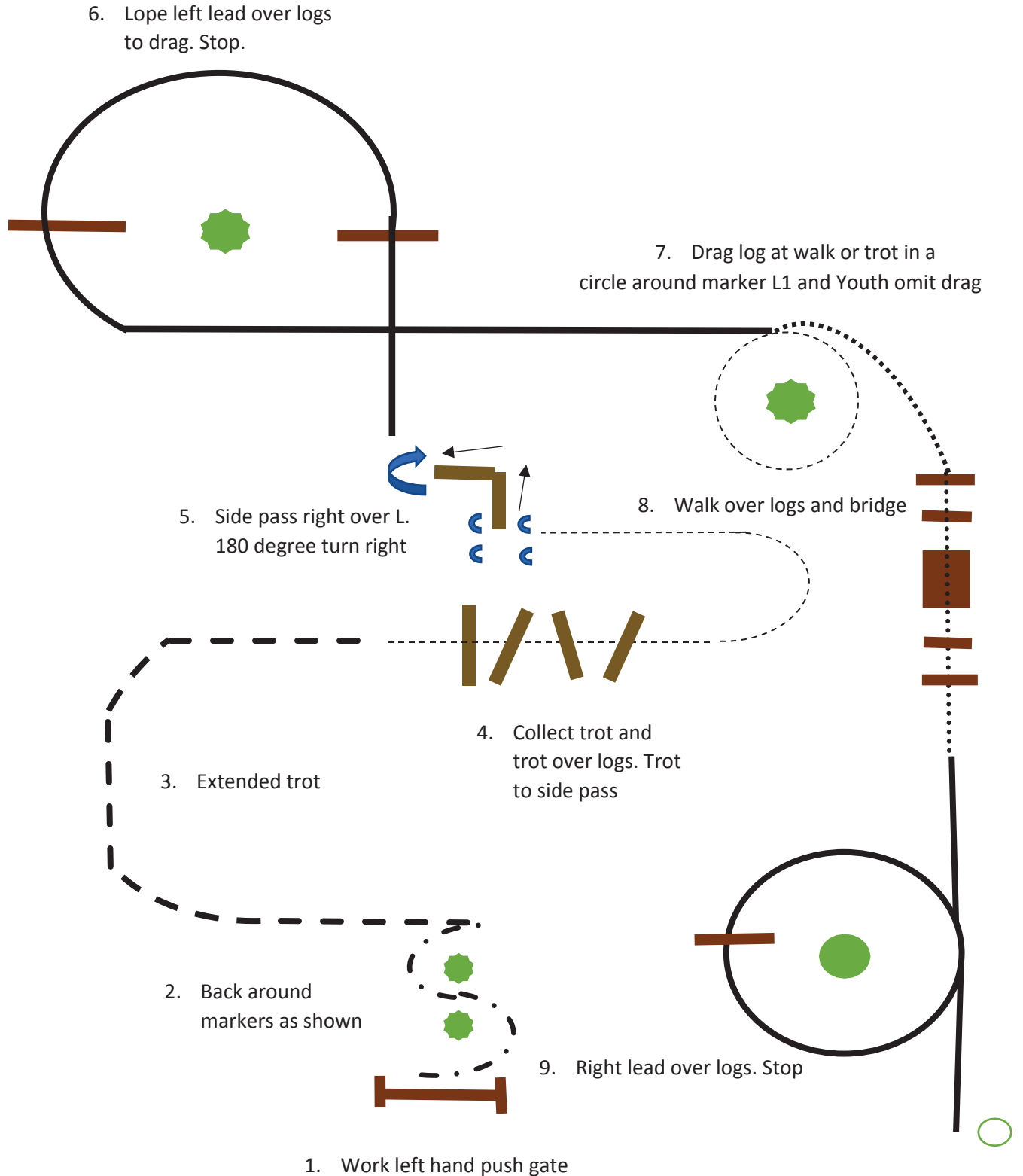

Ranch Riding (Jr, Am, Select, Sr)

Show Date: Thurs June 25

www.HorseShowPatterns.com

www.HorseShowPatterns.com

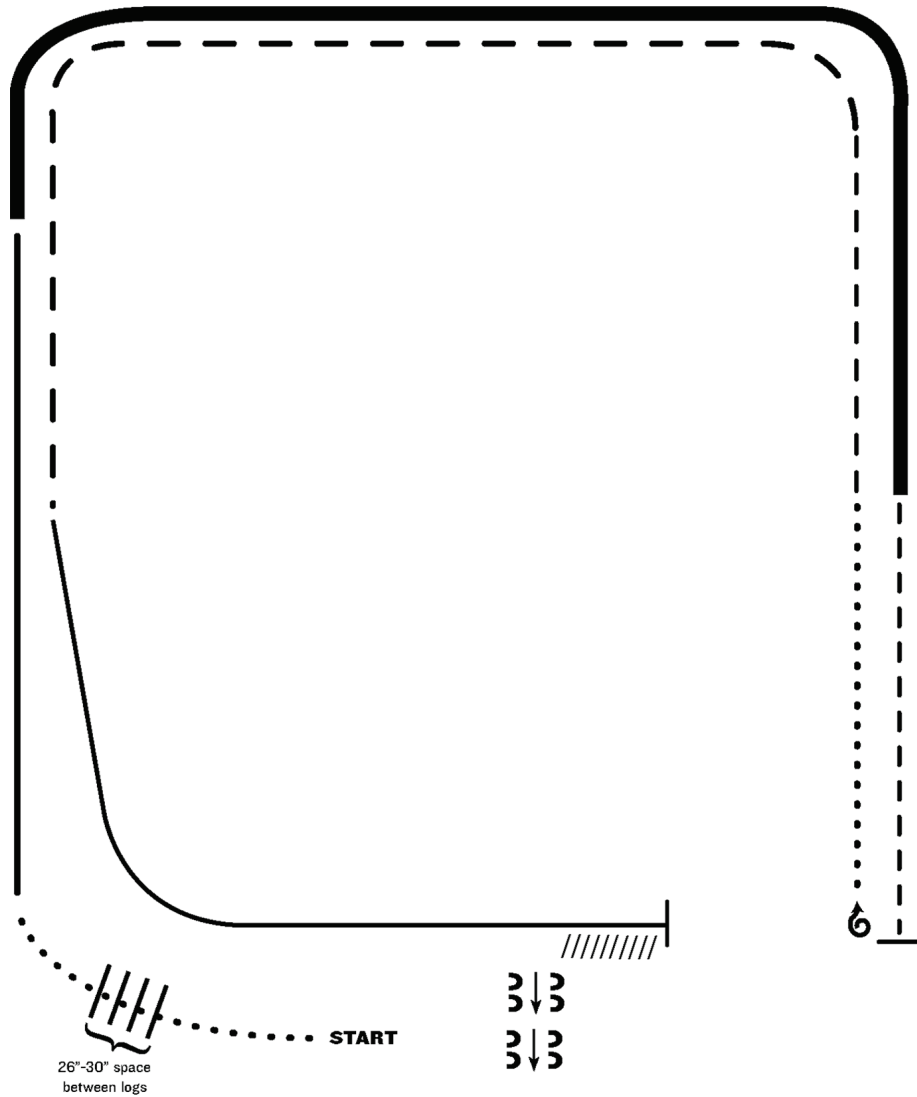

1. Walk
2. Walk over logs
3. Lope right lead
4. Extended lope (right lead)
5. Trot
6. Stop, 1 1/2 turns right
7. Walk
8. Trot
9. Extended trot
10. Lope left lead
11. Stop and Back
12. Side pass right

Note: The drawn description of this pattern is only intended for the general depiction of the pattern. Exhibitors should utilize the arena space to best exhibit their horses.

[RR/AQHA-6]

Pattern Provided by:

Judges

REINING PATTERN 6

Friday June 26 Amateur, Jr, Sr

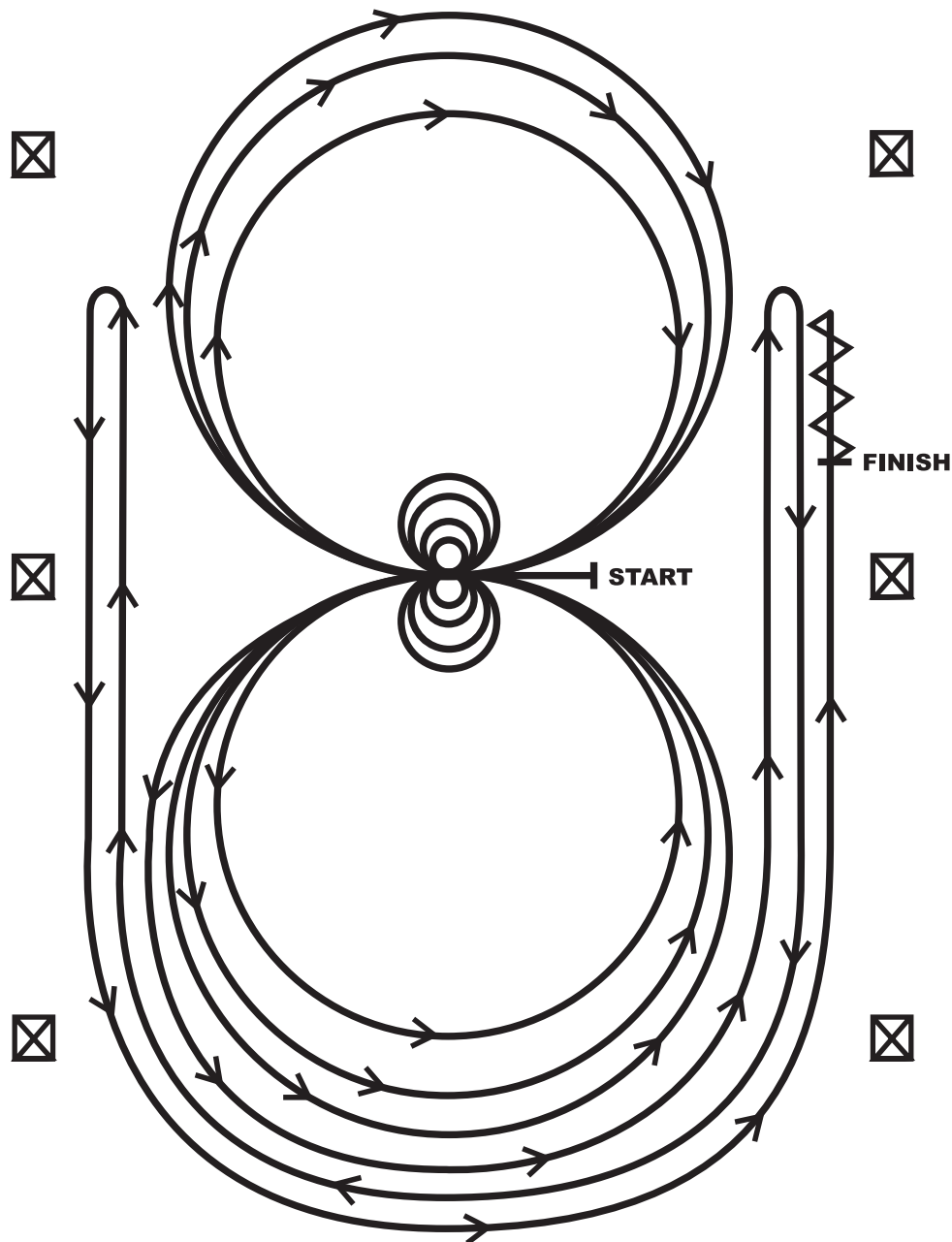

Horses may walk or jog to the center of arena. Horses must walk or stop prior to starting pattern. Beginning at the center of the arena facing the left wall or fence.

1. Complete four spins to the right. Hesitate.
2. Complete four spins to the left. Hesitate.
3. Beginning on the left lead, complete three circles to the left: the first two circles large and fast; the third circle small and slow. Change leads at the center of the arena.
4. Complete three circles to the right: the first two circles large and fast; the third circle small and slow. Change leads at the center of the arena.
5. Begin a large circle to the left but do not close this circle. Run up the right side of the arena past the center marker and do a right rollback at least twenty feet (six meters) from the wall or fence—no hesitation.
6. Continue back around previous circle but do not close this circle. Run up the left side of the arena past the center marker and do a left rollback at least twenty feet (six meters) from the wall or fence—no hesitation.
7. Continue back around previous circle but do not close this circle. Run up the right side of the arena past the center marker and do a sliding stop at least twenty feet (six meters) from the wall or fence. Back up at least ten feet (three meters). Hesitate to demonstrate the completion of the pattern.

WORKING COW HORSE PATTERN 10

Fri June 26 - Lope Away

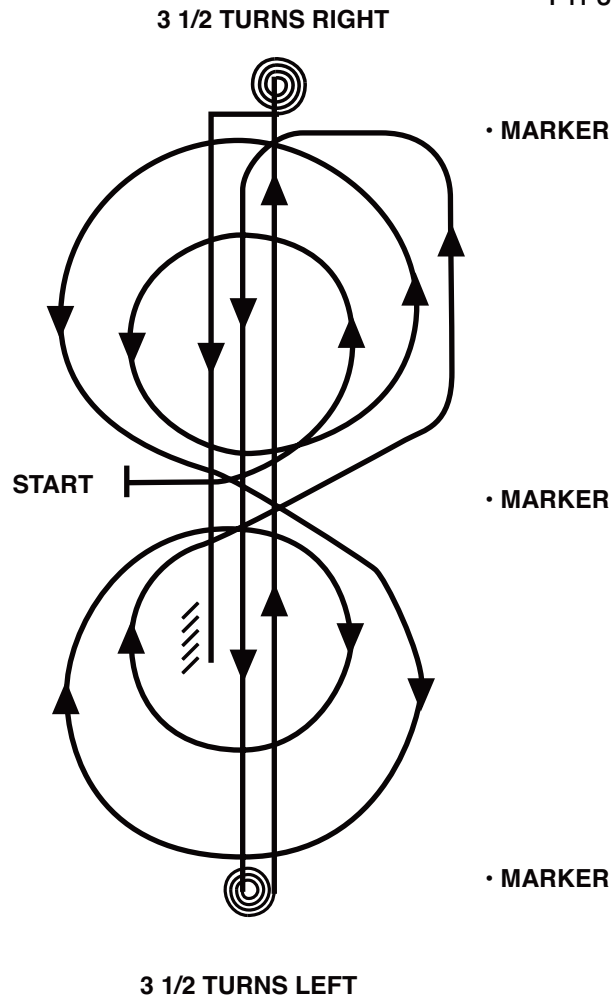

Trot to center of arena, stop. Start pattern facing away from judge.

1. Beginning on the left lead, complete 2 circles to the left; the first circle small and slow, the second circle large and fast.
2. Complete 2 circles to the right; the first circle large and fast, the second circle small and slow. Change leads at the center of arena.
3. Continue around end of arena without breaking gait or changing leads, run down center of arena past end marker, and execute a square sliding stop.
4. Complete 3 1/2 spins to the left.
5. Run down center of arena past end maker, and execute a square sliding stop.
6. Complete 3 1/2 spins to the right.
7. Run down center of arena past center marker, and execute a square sliding stop. Back up at least 10 feet. Hesitate to complete pattern.

Pattern 10

- | | |
|------------------|----------------------|
| 1. Left circles | 4. 3 1/2 left spins |
| 2. Right circles | 5. Stop |
| 3. Stop | 6. 3 1/2 right spins |
| | 7. Stop and back up |

This pattern may be used as a lope-in pattern;
refer to SHW505.2.

RANCH RIDING - PATTERN 10

Fri - 3YR OLD DERBY

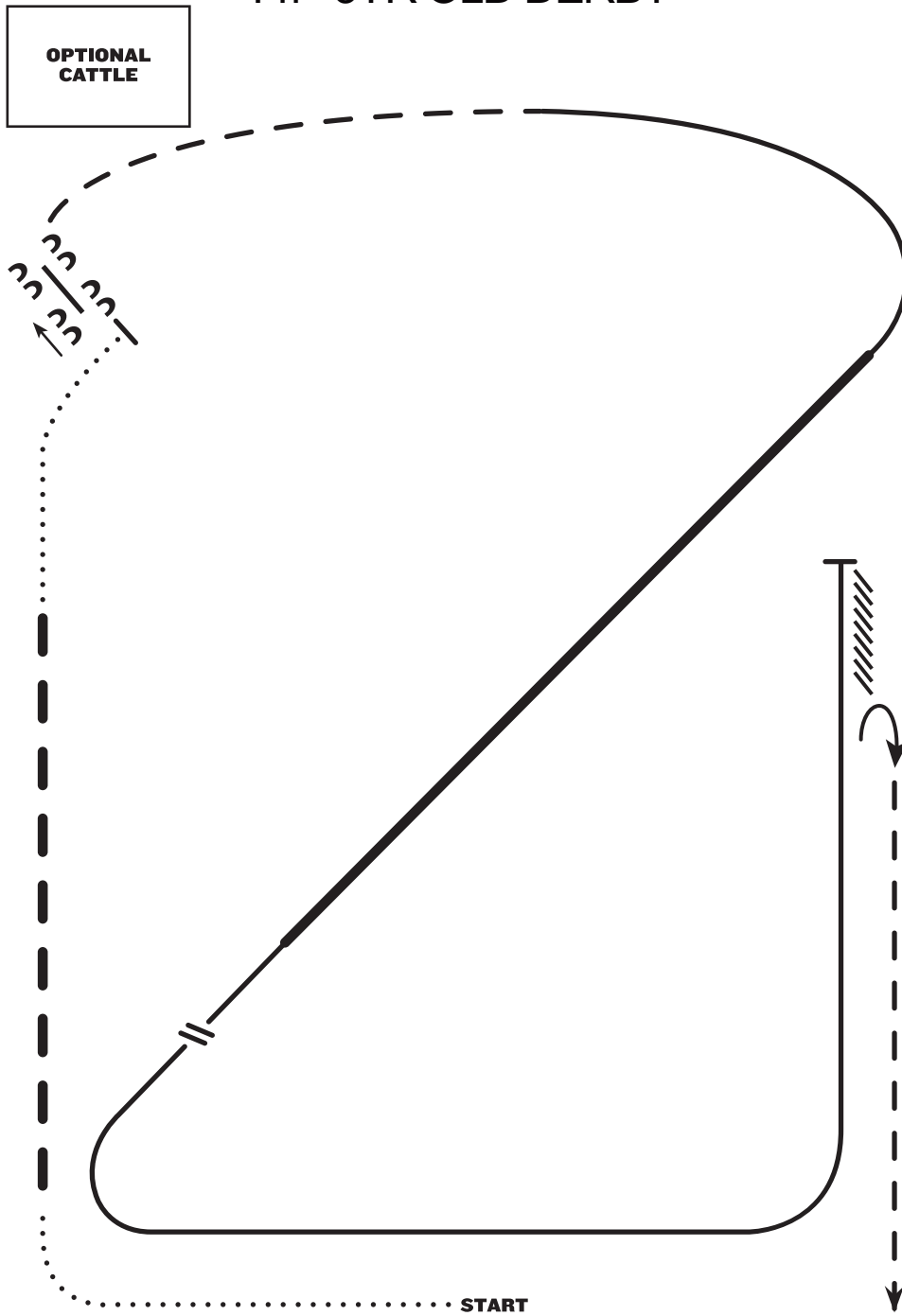

LEGEND	
.....	Walk
.....	Extended Walk
- - -	Trot
- - -	Extended Trot
————	Lope
————	Extended Lope
//////	Back
//	Lead Change

1. Walk
2. Extended trot
3. Walk
4. Stop, side pass left over log
5. Trot
6. Lope right lead
7. Extended lope right lead
8. Collect lope and change leads (simple or flying)
9. Lope left lead
10. Stop and back
11. 1/2 turn right
12. Trot

Note: The drawn description of this pattern is only intended for the general depiction of the pattern. Exhibitors should utilize the arena space to best exhibit their horses.

REINING PATTERN 2

Sat June 27

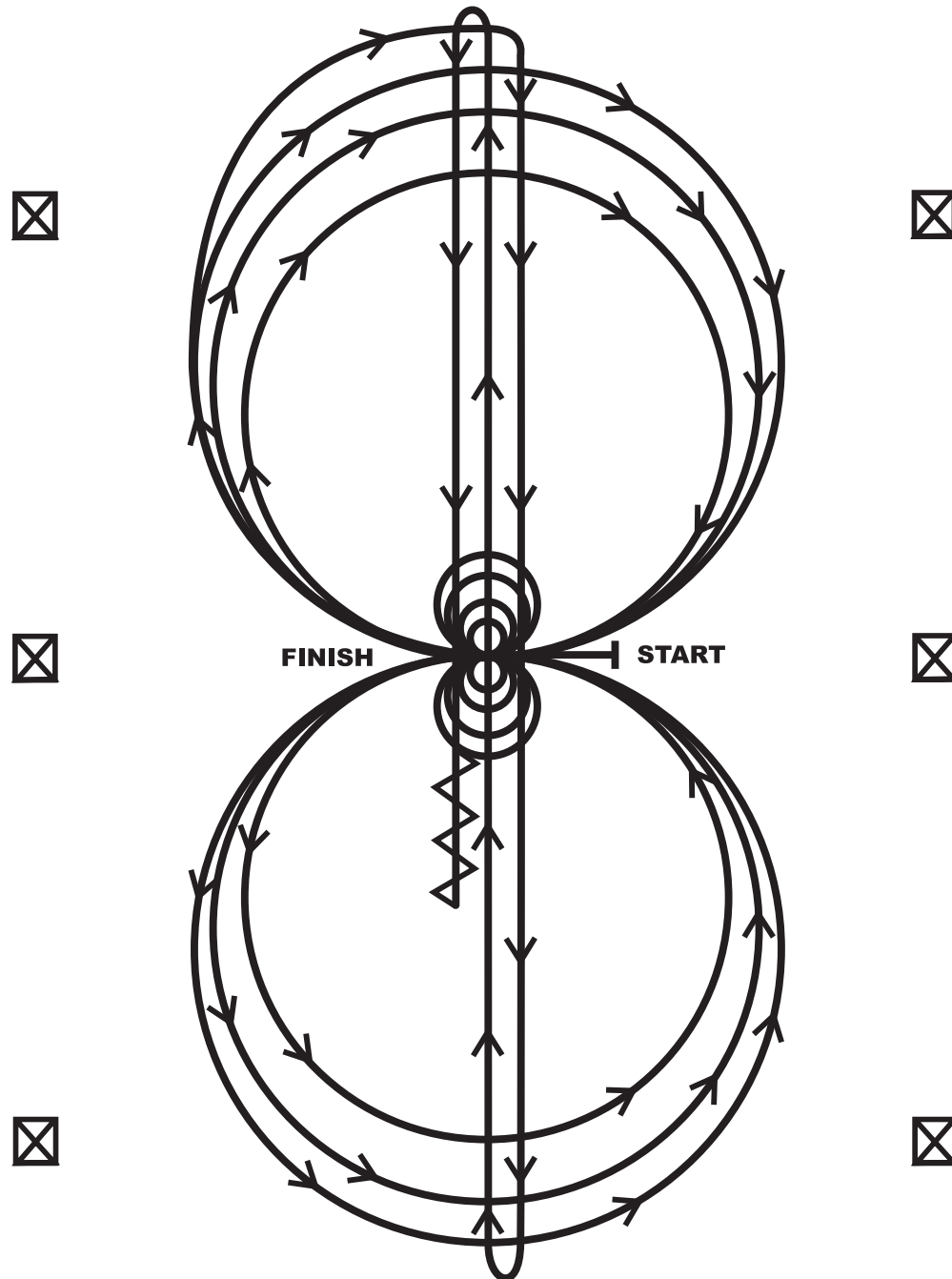

Horses may walk or jog to the center of arena. Horses must walk or stop prior to starting pattern. Beginning at the center of the arena facing the left wall or fence.

1. Beginning on the right lead, complete three circles to the right: the first circle small and slow; the next two circles large and fast. Change leads at the center of the arena.
2. Complete three circles to the left: the first circle small and slow; the next two circles large and fast. Change leads at the center of the arena.
3. Continue around previous circle to the right. At the top of the circle, run down the middle to the far end of the arena past the end marker and do a right rollback—no hesitation.
4. Run up the middle to the opposite end of the arena past the end marker and do a left rollback—no hesitation.
5. Run past the center marker and do a sliding stop. Back up to the center of the arena or at least ten feet (three meters). Hesitate.
6. Complete four spins to the right. Hesitate.
7. Complete four spins to the left. Hesitate to demonstrate the completion of the pattern.

Ranch Trail

Sat June 27 - Walk / Trot

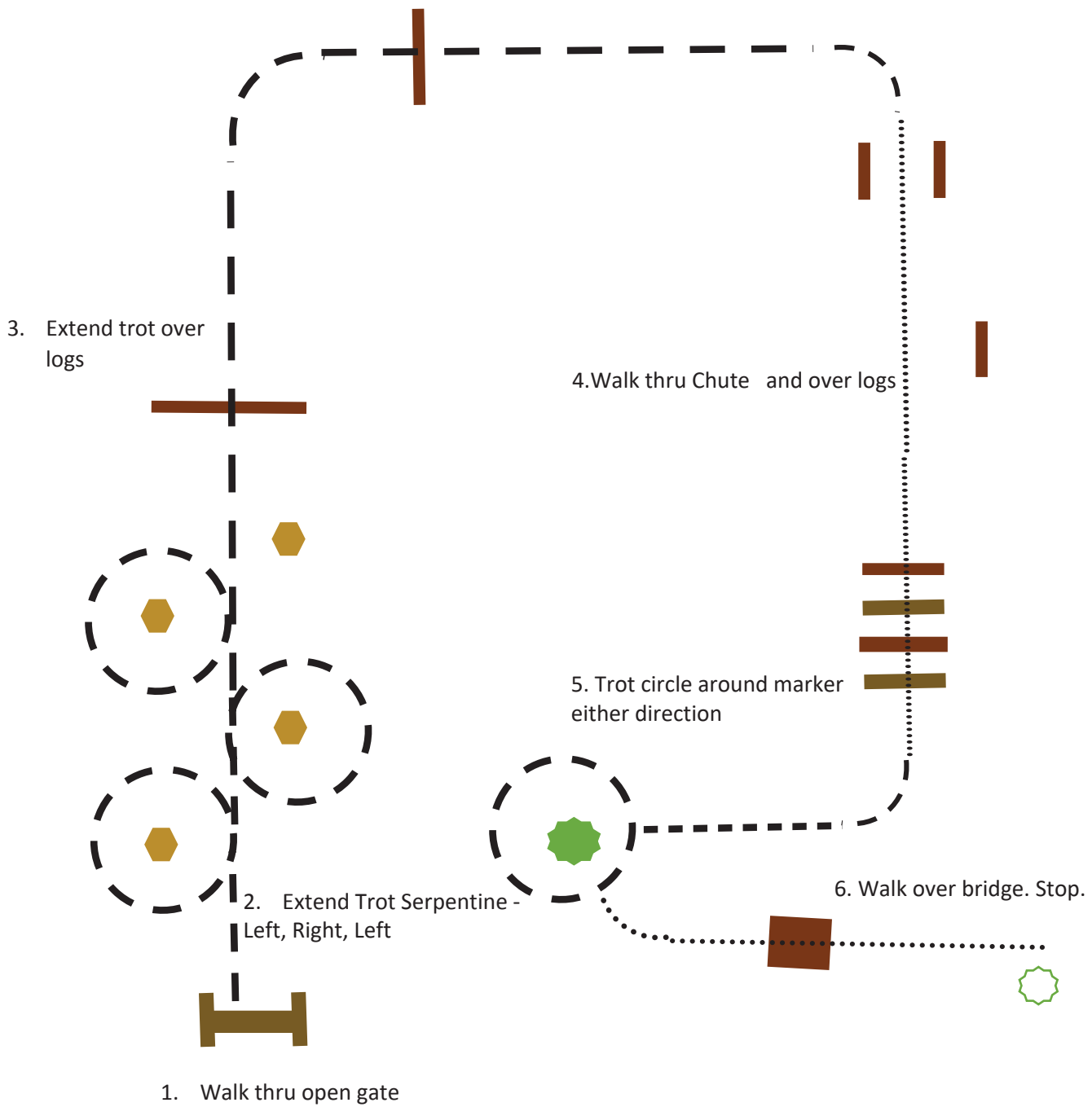

Ranch Trail

Sat June 27 - Sun June 28

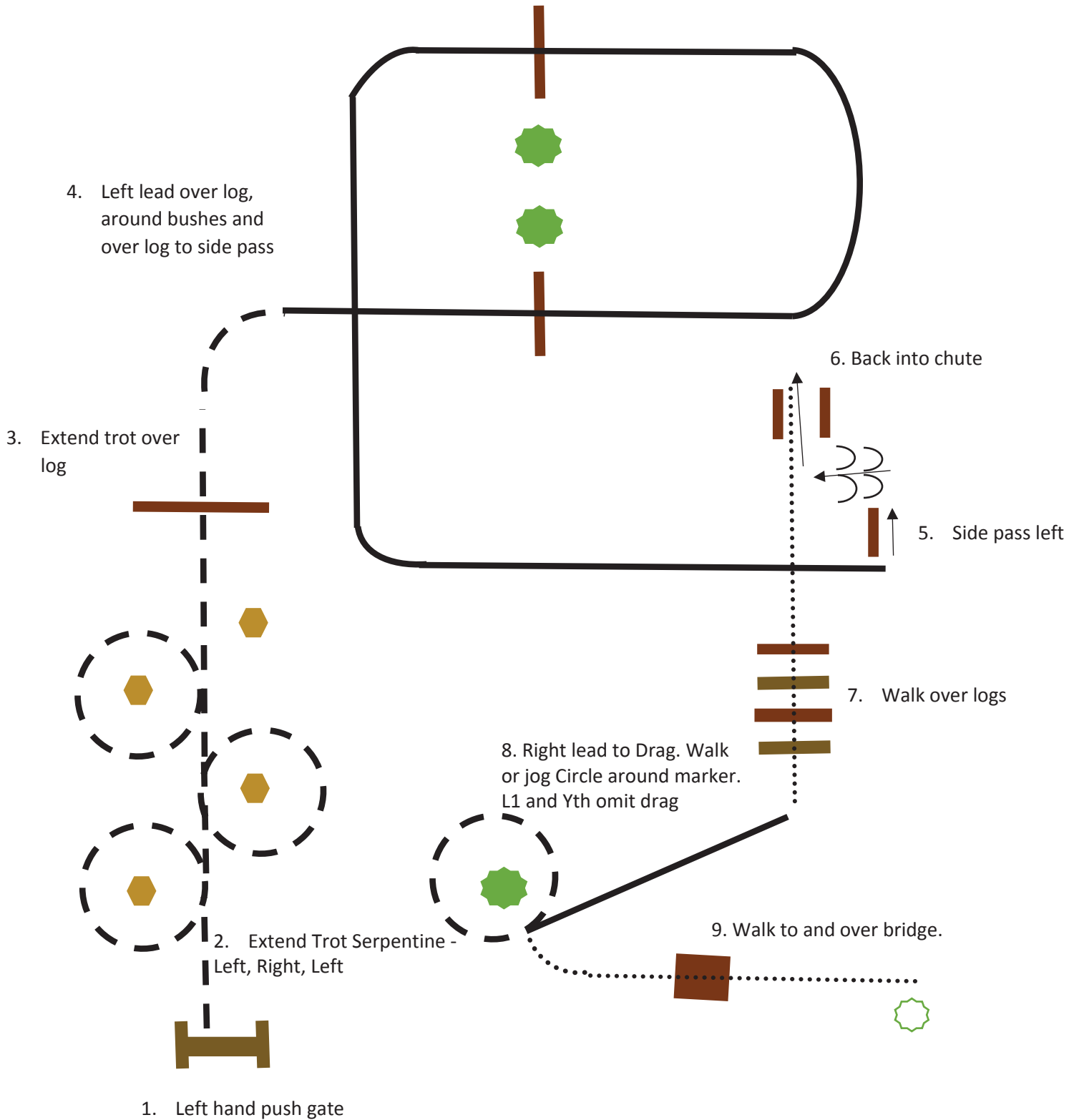

RANCH RIDING - PATTERN 8 Sat June 27

LEGEND

.....	Walk
.....	Extended Walk
- - -	Trot
- - -	Extended Trot
— — —	Lope
— — —	Extended Lope
//////	Back
\\	Lead Change

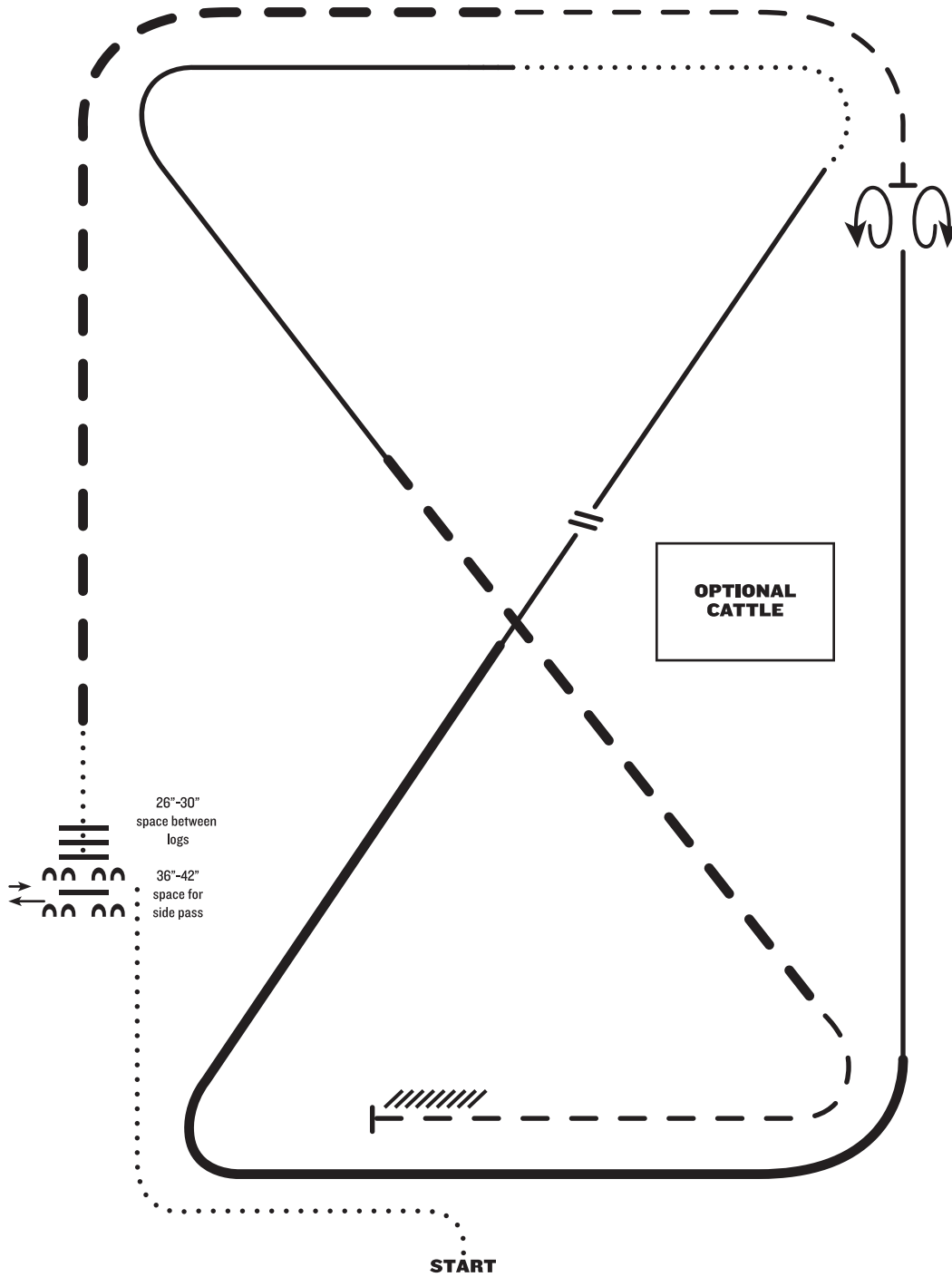

1. Walk
2. Side pass left across first log, side pass 1/2 way to right
3. Walk over logs
4. Extended trot
5. Trot
6. Stop, 360° turn each direction (either direction 1st) (L-R or R-L)
7. Lope right lead
8. Extended lope right lead
9. Collect lope, change leads (simple or flying), continue lope left lead
10. Walk
11. Lope left lead
12. Extended trot
13. Trot
14. Stop and back

Note: The drawn description of this pattern is only intended for the general depiction of the pattern. Exhibitors should utilize the arena space to best exhibit their horses.

REINING PATTERN 7

Sun June 28

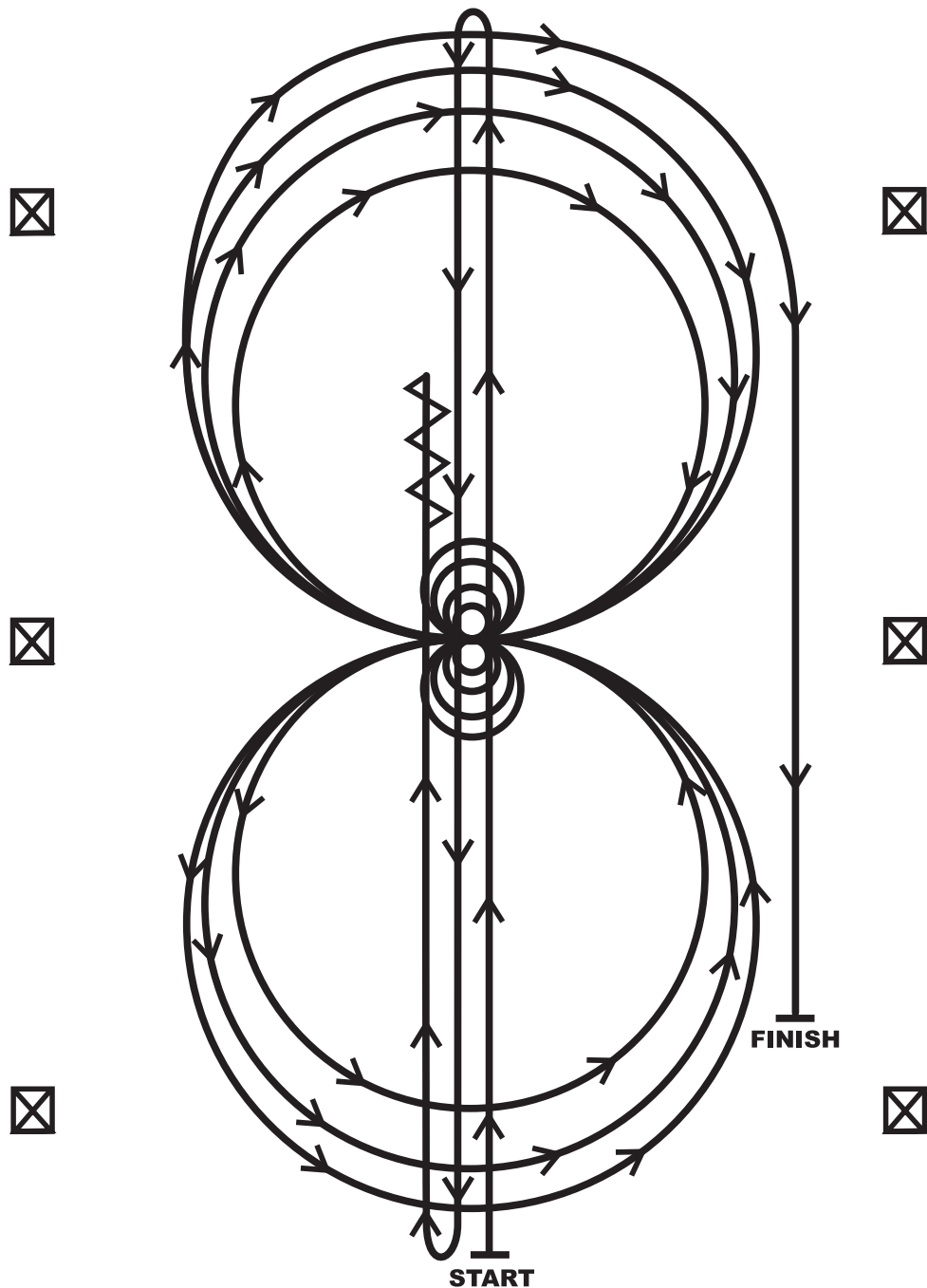

1. Run at speed to the far end of the arena past the end marker and do a left rollback—no hesitation.
2. Run to the opposite end of the arena past the end marker and do a right rollback—no hesitation.
3. Run past the center marker and do a sliding stop. Back up to the center of the arena or at least ten feet (three meters). Hesitate.
4. Complete four spins to the right. Hesitate.
5. Complete four and one-quarter spins to the left so that horse is facing left wall or fence. Hesitate.
6. Beginning on the right lead, complete three circles to the right: the first two circles large fast; the third circle small and slow. Change leads at the center of the arena.
7. Complete three circles to the left: the first two circles large fast; the third circle small and slow. Change leads at the center of the arena.
8. Begin a large circle to the right but do not close this circle. Run straight down the right side of the arena past the center marker and do a sliding stop at least twenty feet (six meters) from the wall or fence. Hesitate to demonstrate completion of the pattern.

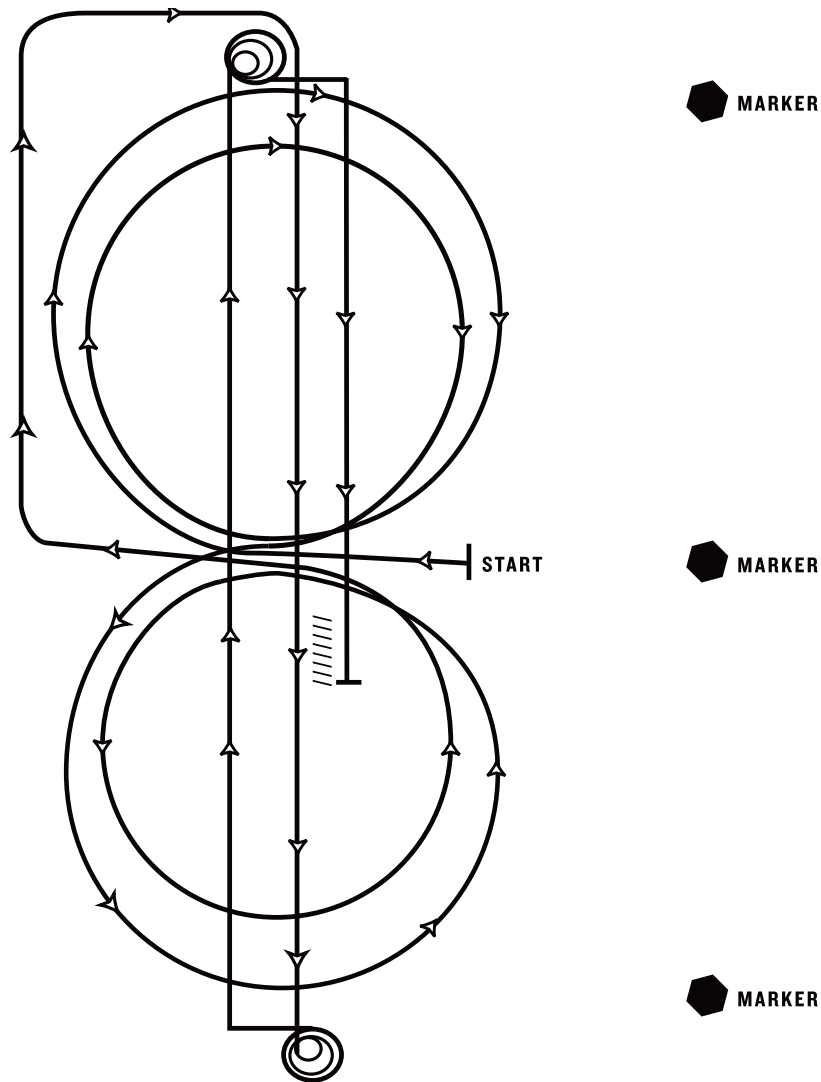

Trot to center of arena, stop. Start pattern facing toward judge.

1. Beginning on the right lead complete 2 circles to the right; the first circle large and fast and the second small and slow. Change leads at the center of the arena.
2. Complete 2 circles to the left, the first circle large and fast and the second small and slow. Change leads at the center of the arena.
3. Continue around end of arena without breaking gait or changing leads, run down center of arena past end marker, and execute a square sliding stop.
4. Complete 3 1/2 spins to the left.
5. Run down center of arena past end marker, and execute a square sliding stop.
6. Complete 3 1/2 spins to the right.
7. Run down center of arena past center marker, and execute a square sliding stop. Back up at least 10 feet. Hesitate to complete pattern.

Pattern 12

- | | |
|------------------|----------------------|
| 1. Right circles | 4. 3 1/2 left spins |
| 2. Left circles | 5. Stop |
| 3. Stop | 6. 3 1/2 right spins |
| | 7. Stop and back up |

This pattern may be used as a lope-in pattern; refer to SHW505.2.

RANCH RIDING - PATTERN 7

Sun June 28

LEGEND

.....	Walk
.....	Extended Walk
- - -	Trot
- - -	Extended Trot
— — —	Lope
— — —	Extended Lope
//////	Back
\\	Lead Change

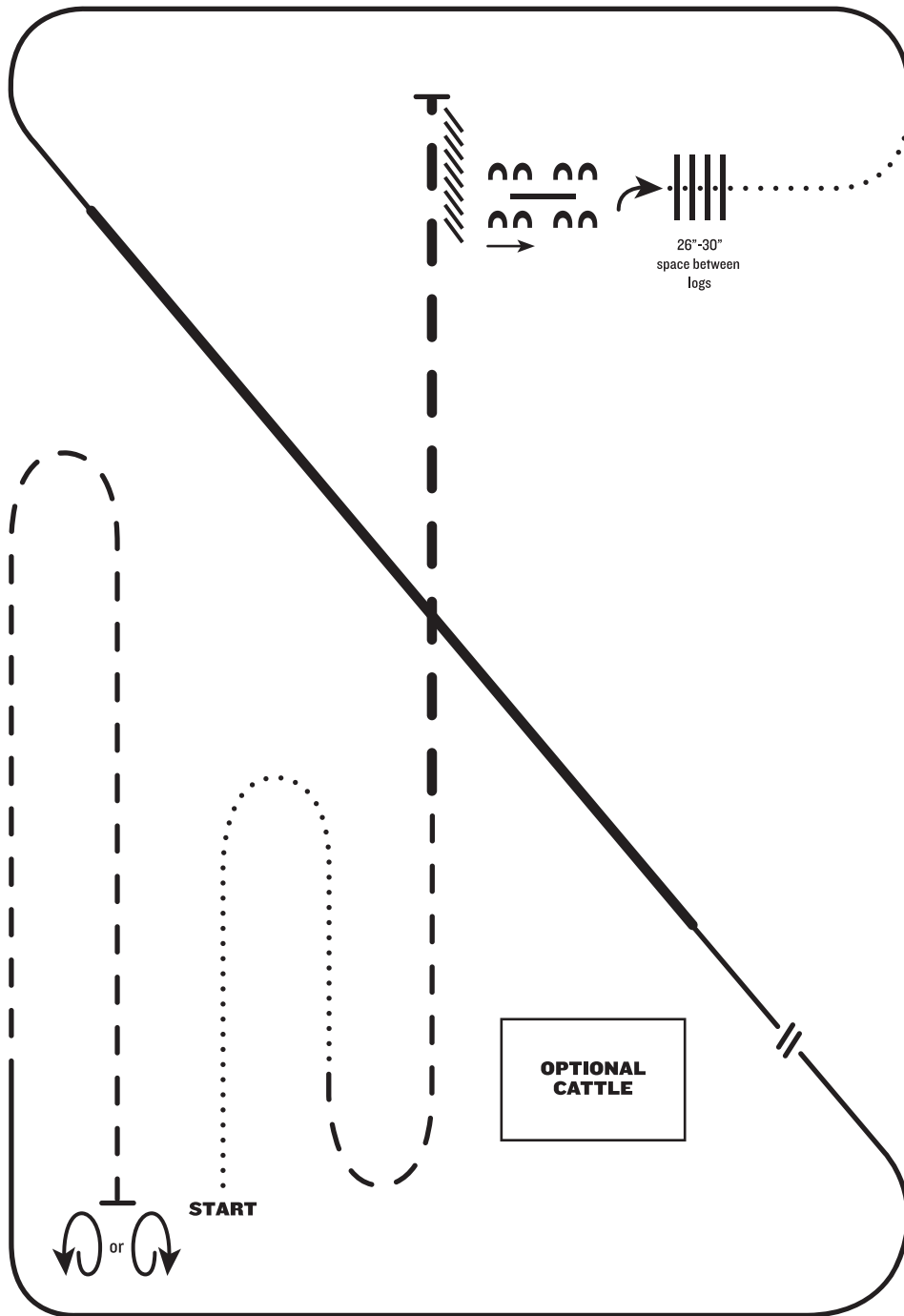

1. Walk
2. Trot
3. Extended trot
4. Stop and back
5. Side pass right over log
6. 1/4 turn right, walk over logs
7. Walk
8. Lope left lead
9. Extended lope left lead
10. Collect lope, change leads (simple or flying)
11. Lope right lead
12. Trot
13. Stop, one 360° turn either direction

Note: The drawn description of this pattern is only intended for the general depiction of the pattern. Exhibitors should utilize the arena space to best exhibit their horses.

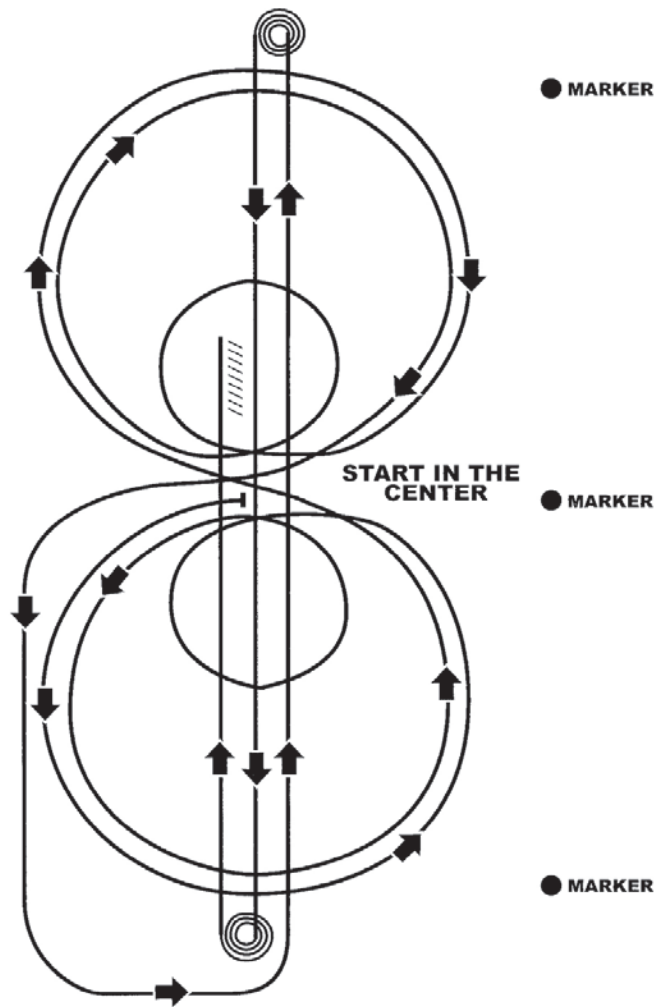

Mandatory Marker Along Fence or Wall

Trot to center of arena and stop. Start pattern facing toward judge.

1. Pick up left lead, complete three circles to the left. The first one large and fast, the second small and slow, the third large and fast. Change leads at center of arena.
2. Complete three circles to the right. The first one large and fast, the second small and slow, the third large and fast. Change leads at center of arena.
3. Do not stop, continue on to run downs. Run to far end past the marker to a sliding stop. Hesitate
4. Complete 3 1/2 spins to the left. Hesitate.
5. Run to far end past the marker to a sliding stop. Hesitate
6. Complete 3 1/2 spins to the right. Hesitate.
7. Run past center marker to a sliding stop. Hesitate. Back at least 10 feet. Hesitate to complete pattern.

Pattern 2

- | | |
|------------------|----------------------|
| 1. Left circles | 4. 3 1/2 left spins |
| 2. Right circles | 5. Stop |
| 3. Stop | 6. 3 1/2 right spins |
| | 7. Stop and back up |

This pattern may be used as a lope in pattern; refer to SHW505.2.

Level 1 Youth, Level 1 Amateur, L1 Select, L1 Horse Non Pro Showmanship

Show Date: Tues June 30

w w w . H o r s e S h o w P a t t e r n s . c o m

w w w . H o r s e S h o w P a t t e r n s . c o m

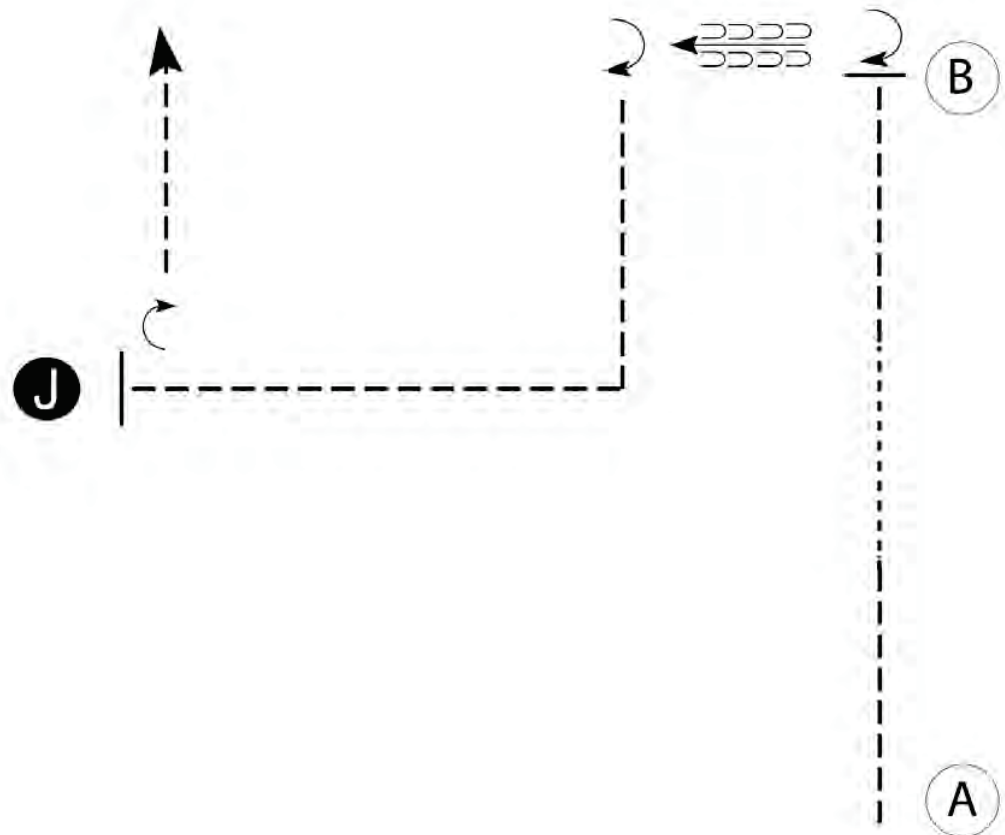

Be ready at A.

1. Trot 1/3 of the line, then walk 1/3 of the line then trot the final 1/3 of the line.
2. Stop with horse's hip even with B then perform a 1/4 turn.
3. Back 2 horse lengths then perform a 1/4 turn.
4. Trot to judge as shown.
5. Stop and set up at Judge.
6. Inspection.
7. When dismissed, perform a 1/4 turn and trot to exit.

Walk	⋯⋯⋯
Trot	- - - - -
Back	← - - - - ← - - - - ← - - - -
Marker	Ⓚ
Judge	●

[S/1-119]

Pattern Provided by: Judges

Youth, Amateur & Select Showmanship

Show Date: Tues June 30

w w w . H o r s e S h o w P a t t e r n s . c o m

w w w . H o r s e S h o w P a t t e r n s . c o m

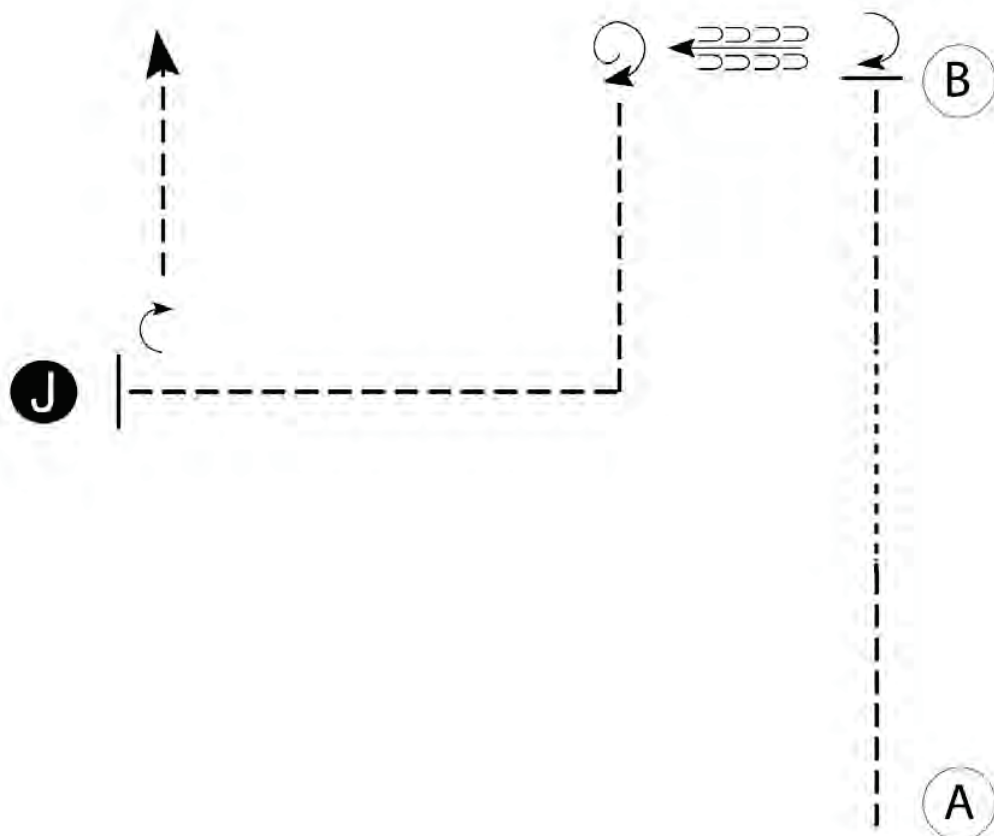

Be ready at A.

1. Trot 1/3 of the line, then walk 1/3 of the line then trot the final 1/3 of the line.
2. Stop with horse's hip even with B then perform a 1/4 turn.
3. Back 2 horse lengths then perform a 1 1/4 turn.
4. Trot to judge as shown.
5. Stop and set up at Judge.
6. Inspection.
7. When dismissed, perform a 1/4 turn and trot to exit.

Walk - - - - -
Trot - . - . -
Back ← - - - - -
Marker (B)
Judge (J)

[S/2-119]

Pattern Provided by:Judges

Western Riding (Jr/Sr/Yth/Am/Select)

Show Date: Tues June 30

w w w . H o r s e S h o w P a t t e r n s . c o m

w w w . H o r s e S h o w P a t t e r n s . c o m

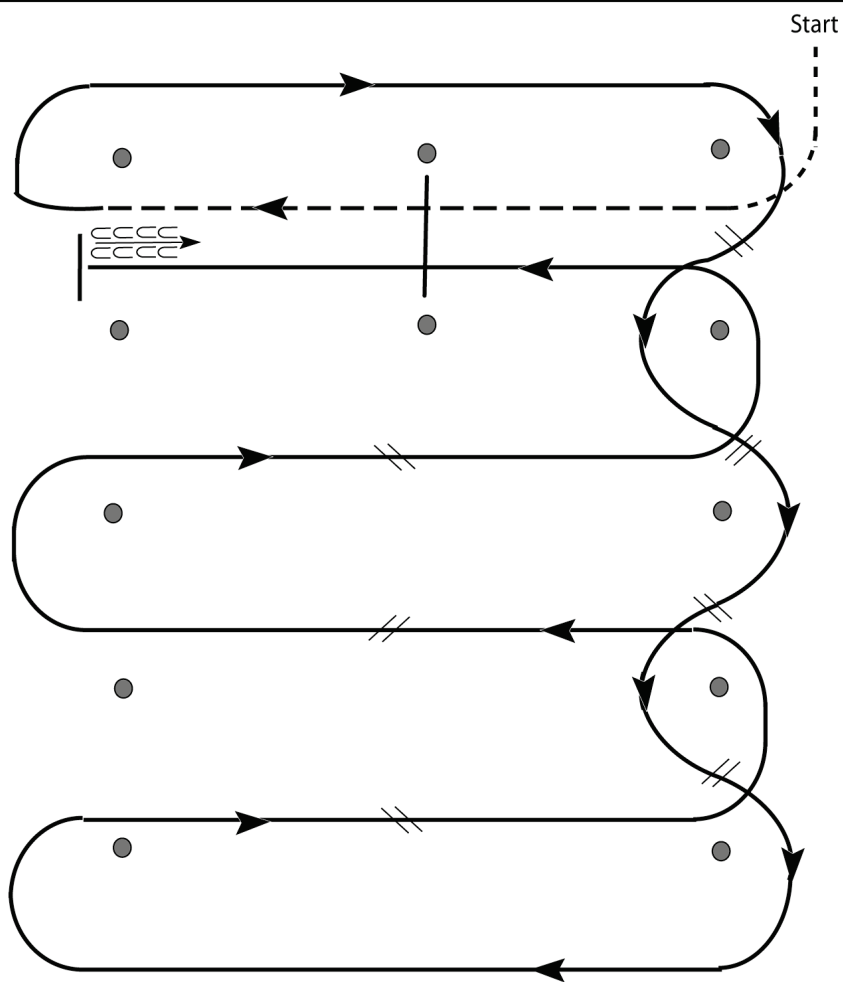

1. Walk, transition to jog, jog over log.
2. Transition to right.
3. First line change.
4. Second line change.
5. Third line change.
6. Fourth line change.
7. First crossing change.
8. Second crossing change.
9. Third crossing change.
10. Lope over log.
11. Lope, stop and back.

[WR/OP-4]

Pattern Provided by:

Judges

Western Riding (Level 1 - Open, Am, Yth)

Show Date: Tues June 30

w w w . H o r s e S h o w P a t t e r n s . c o m

w w w . H o r s e S h o w P a t t e r n s . c o m

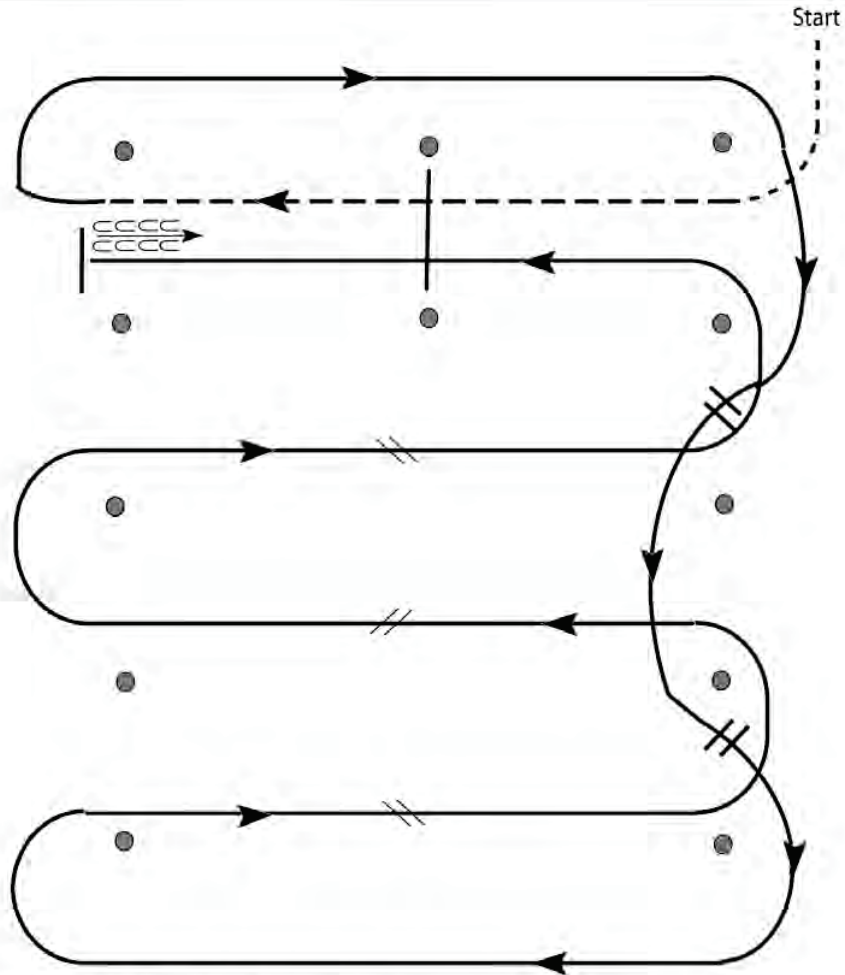

1. Walk, transition to jog, jog over log.
2. Transition to right lead and lope around end.
3. First line change.
4. Second line change. Lope around end of arena.
5. First crossing change.
6. Second crossing change.
7. Third crossing change.
8. Lope over log.
9. Lope, stop and back.

[WR/GP-4]

Pattern Provided by:

Judges

**2026
The Celebration**

**ALL WALK/TROT
TRAIL CLASSES**

TUESDAY

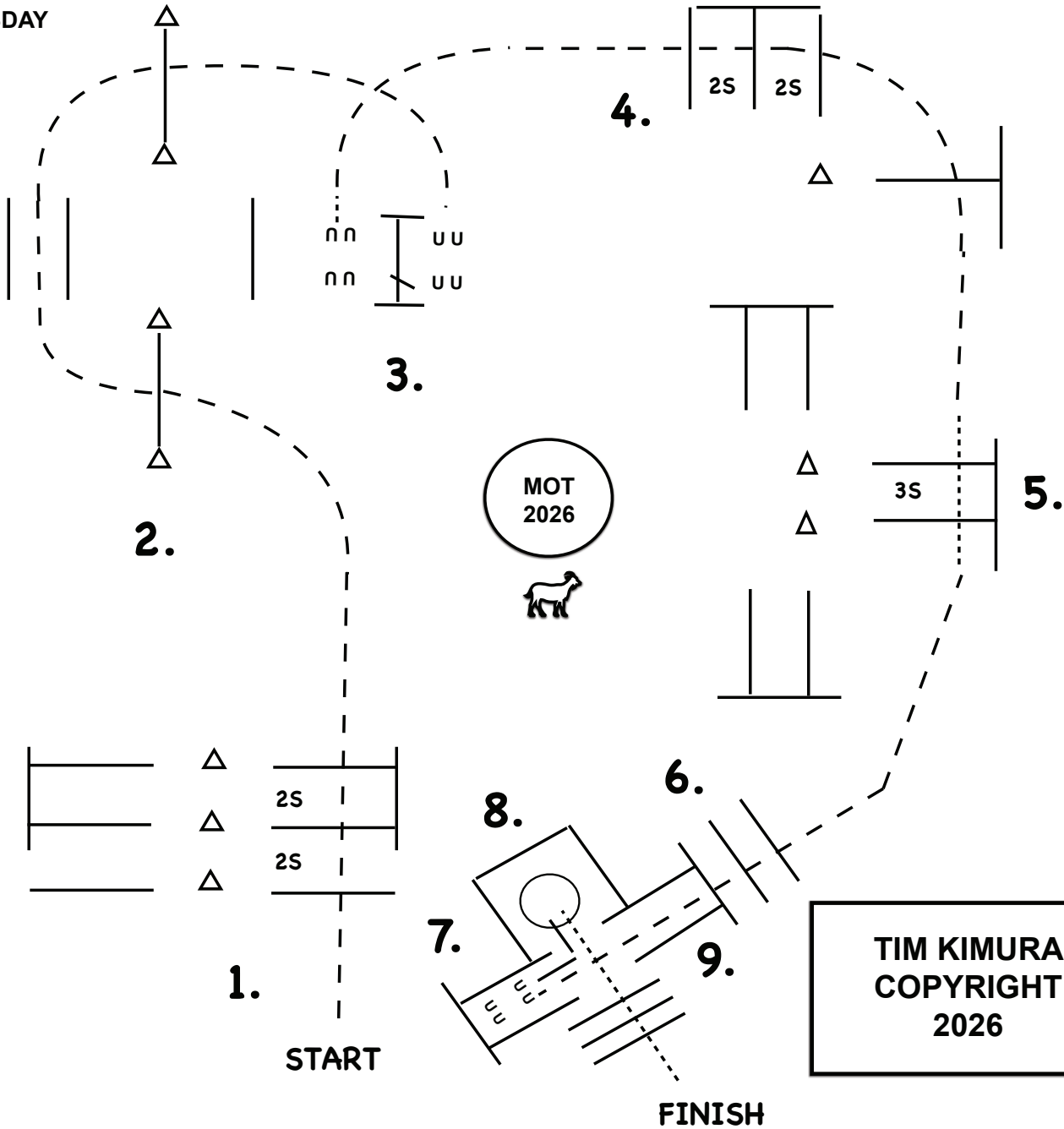

1. JOG OVER POLES.
2. JOG THROUGH SERPENTINE, JOG THROUGH CHUTE, JOG OVER POLES.
3. JOG UP TO GATE, WORK GATE RIGHT HAND.
4. YOU MAY WALK FORWARD, THEN JOG OVER POLES.
5. STOP OR BREAK TO THE WALK, WALK OVER POLES.
6. JOG OVER POLES, JOG INTO CHUTE.
7. BACK BETWEEN POLES, BACK AROUND CORNER, BACK INTO BOX.
8. EXECUTE A 360 TURN EITHER WAY.
9. WALK OUT BOX, WALK OVER POLES.

**2026
The Celebration**

**L1 TRAIL, L1 AMATEUR,
L1 YOUTH, AND JUNIOR TRAIL**

TUESDAY

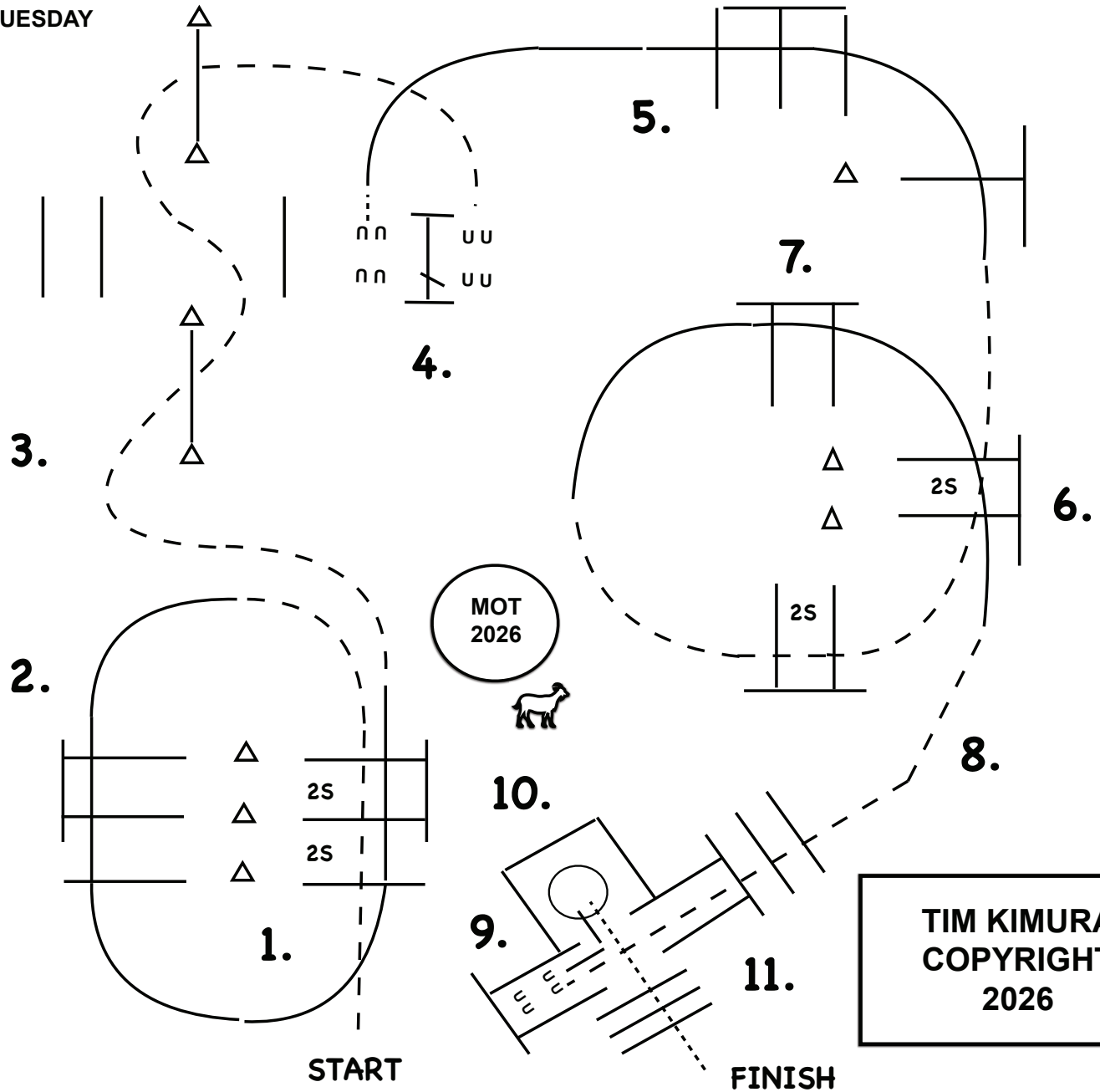

1. JOG OVER POLES.
2. LOPE OVER POLES (LEFT LEAD).
3. BREAK TO THE JOG, JOG THROUGH SERPENTINE, JOG OVER POLES.
4. JOG UP TO GATE, WORK GATE RIGHT HAND.
5. YOU MAY WALK FORWARD, LOPE OVER POLES (RIGHT LEAD).
6. BREAK TO THE JOG, JOG OVER POLES.
7. LOPE OVER POLES (RIGHT LEAD).
8. BREAK TO THE JOG, JOG OVER POLES, JOG INTO CHUTE.
9. BACK BETWEEN POLES, BACK AROUND CORNER, BACK INTO BOX.
10. EXECUTE A 360 TURN EITHER WAY.
11. WALK OUT BOX, WALK OVER POLES.

**TIM KIMURA
COPYRIGHT
2026**

Walk/Trot Horsemanship

Show Date: Wed July 1

www.HorseShowPatterns.com

www.HorseShowPatterns.com

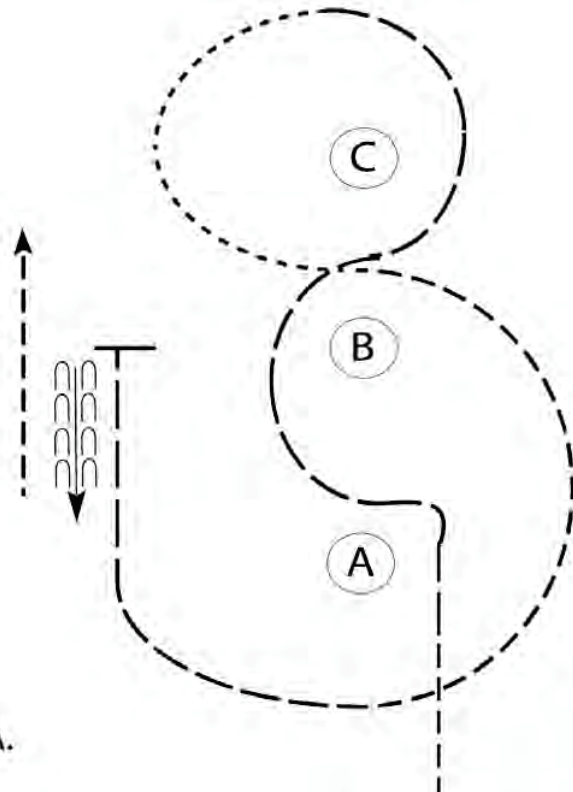

Be ready before A.

1. Begin at a jog and build to and extended jog by the time you reach A. Extend the jog through A, B and C as shown.
2. At the top of C, walk in a half circle.
3. Pick up the jog between B and C and jog in a half circle.
4. When below A, extend the jog around the corner and until even with B.
5. Stop and back approximately one horse length.
6. Jog to exit.

Walk	-----
Jog	- - - - -
Extended Jog	-----
Lope	
Lead Change	⚡
Back	←
Marker	⊙ B

[WH/WT-113]

Pattern Provided by:

JUDGES

Level 1 Yth, Level 1 Amateur, L1 Select, L1 Horse Non Pro

Horsemanship

Show Date: Wed July 1

www.HorseShowPatterns.com

www.HorseShowPatterns.com

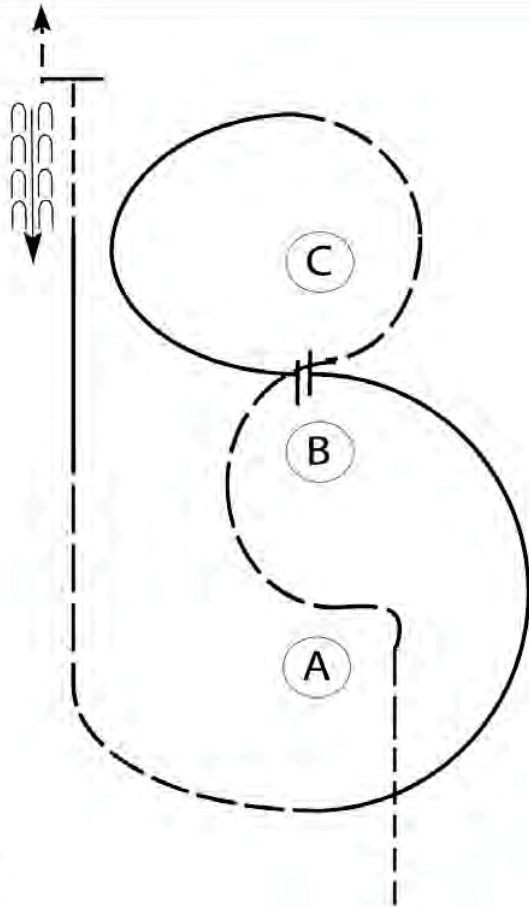

Be ready before A.

1. Begin at a jog and build to and extended jog by the time you reach A. Extend the jog through A, B and C as shown.
2. At the top of C, pick up a left lead lope in a half circle.
3. Perform a simple lead change between B and C.
4. Lope right lead in a half circle.
5. When below A, extend the jog around the corner and until even with B.
5. Lope left lead until even with C. Then jog past C and stop.
6. Back approximately one horse length.
7. Jog to exit.

Walk	-----
Jog	- - - - -
Extended Jog	— — — —
Lope	
Lead Change	⚡
Back	← C C C C C
Marker	(B)

[WH/1-113]

Pattern Provided by:

JUDGES

Youth, Amateur, Select Horsemanship

Show Date: Wed July 1

www.HorseShowPatterns.com

www.HorseShowPatterns.com

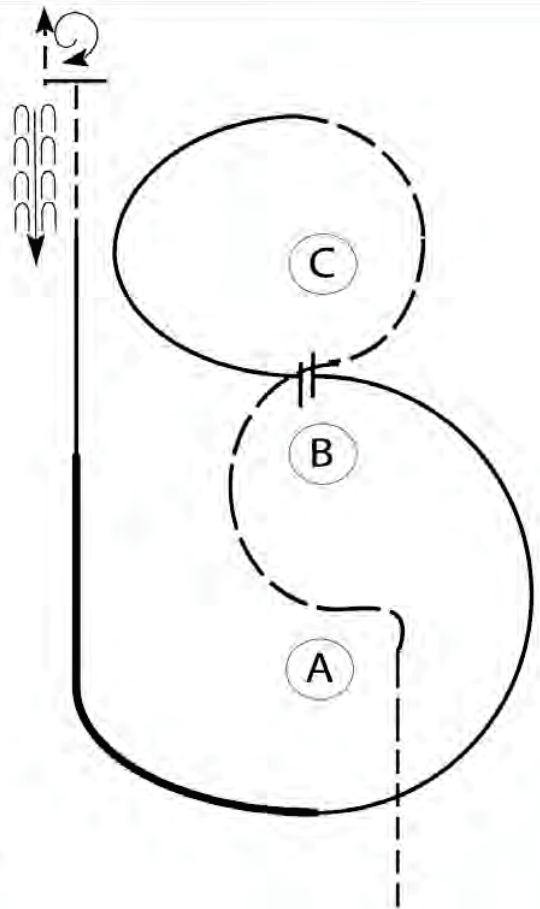

Be ready before A.

1. Begin at a jog and build to and extended jog by the time you reach A. Extend the jog through A, B and C as shown.
2. At the top of C, pick up a left lead lope in a half circle.
3. Change leads between B and C.
4. Lope right lead in a half circle. When below A, extend the lope around the corner and until even with B.
5. Slow to a lope until even with C. Then jog past C and stop.
6. Perform a full turn to the right then back approximately one horse length.
7. Jog to exit.

Walk	-----
Jog	- - - - -
Extended Jog	—————
Lope	
Lead Change	
Back	
Marker	

[WH/3-113]

Pattern Provided by:
JUDGES

Walk Trot Equitation

Show Date: Wed July 1

www.HorseShowPatterns.com

www.HorseShowPatterns.com

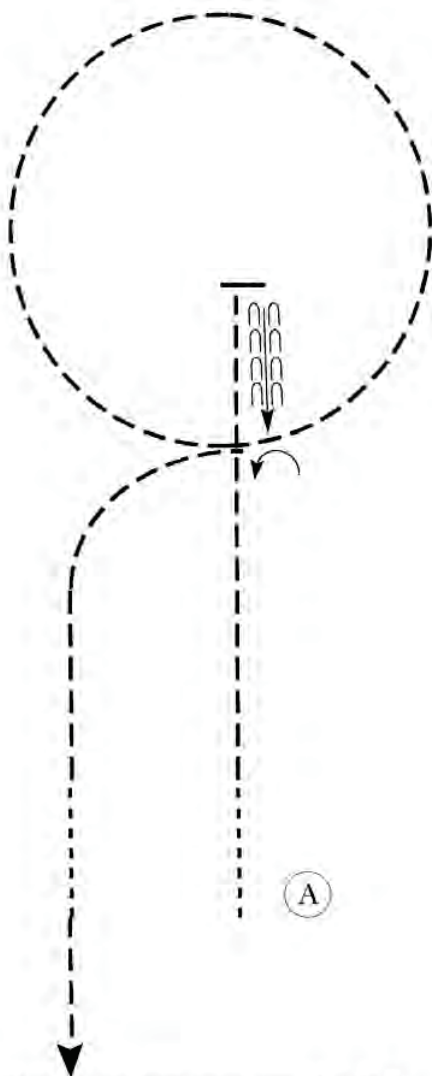

Be ready at A.

1. Walk two horse lengths then posting trot on the left diagonal past the center of the arena.
2. Stop and back approximately two horse lengths.
3. Perform a 90 degree turn on the forehand to the left.
4. Trot a circle on the left diagonal.
5. Change diagonals then posting trot on the right diagonal then walk two horse lengths. Pattern is complete, exit at a sitting trot.

Walk	-----
Trot	- - - - -
Extended Trot	- - - - -
Canter	—————
Leg Yield	
Lead Change	↘ ↘ ↘
Back	← ← ←
Marker	Ⓚ
Sidepass	← ←
Hand Gallop	—————

[HSE/WT-82]

Pattern Provided by: Judges

Level 1 Youth, L1 Amateur, L1 Horse Non Pro Equitation

Show Date: Wed July 1

w w w . H o r s e S h o w P a t t e r n s . c o m

w w w . H o r s e S h o w P a t t e r n s . c o m

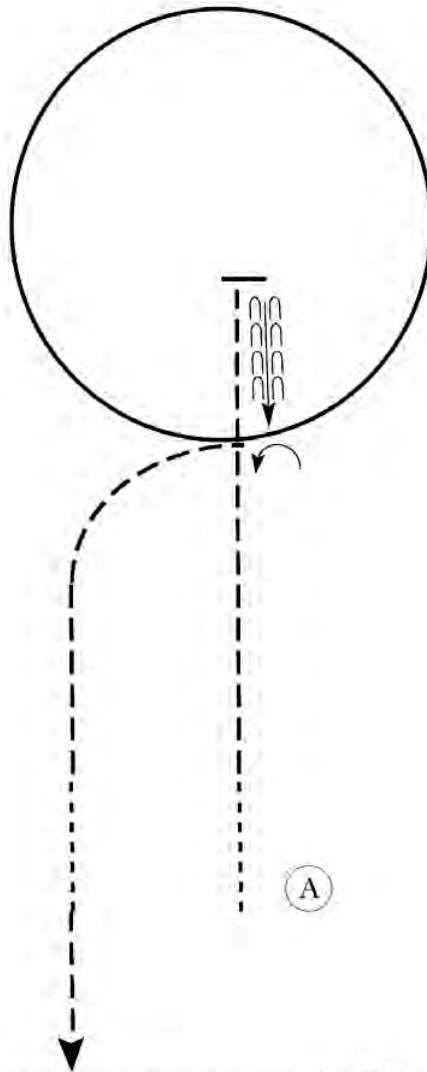

Be ready at A.

1. Walk two horse lengths then posting trot on the left diagonal past the center of the arena.
2. Stop and back approximately two horse lengths.
3. Perform a 90 degree turn on the forehand to the left.
4. Canter a circle on the right lead.
5. Posting trot on the right diagonal then walk two horse lengths. Pattern is complete, exit at a sitting trot.

Walk	-----
Trot	- - - - -
Extended Trot	— — — — —
Canter	—————
Leg Yield	
Lead Change	↘
Back	←←←←←
Marker	⊙ B
Sidepass	← ←
Hand Gallop	———

[HSE/1-82]

Pattern Provided by: Judges

Youth, Amateur & Select Equitation

Show Date: Wed July 1

www.HorseShowPatterns.com

www.HorseShowPatterns.com

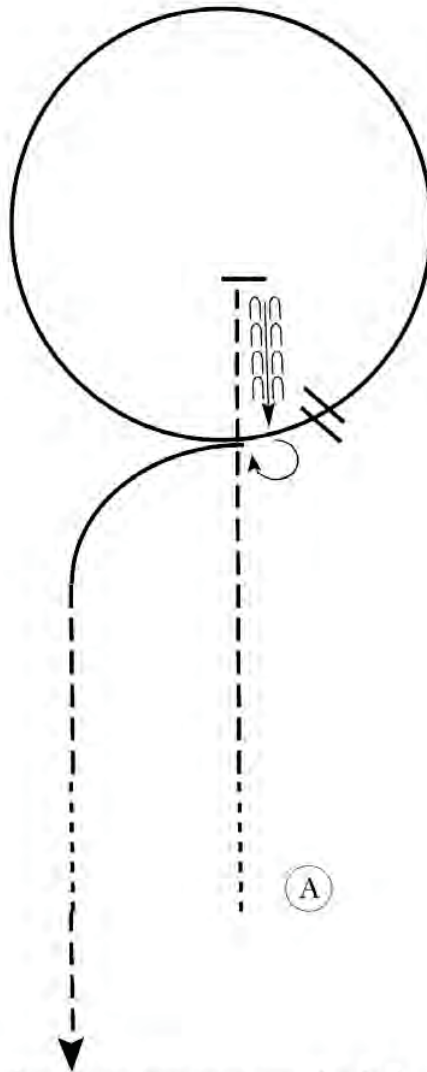

Be ready at A.

1. Walk two horse lengths then posting trot on the left diagonal past the center of the arena.
2. Stop and back approximately two horse lengths.
3. Perform a 270 degree turn on the forehand to the right.
4. Canter a circle on the right lead.
5. Perform a simple or flying lead change.
6. Canter on the left lead.
7. Posting trot on the right diagonal then walk two horse lengths. Pattern is complete, exit at a sitting trot.

Walk	-----
Trot	- - - - -
Extended Trot	- - - - -
Canter	—————
Leg Yield	
Lead Change	↘↘↘
Back	←←←
Marker	ⓑ
Sidepass	←←
Hand Gallop	———

[HSE/3-82]

Pattern Provided by: Judges

**2026
The Celebration**

**YOUTH AND SENIOR TRAIL
SELECT AND AMATEUR TRAIL**

WEDNESDAY

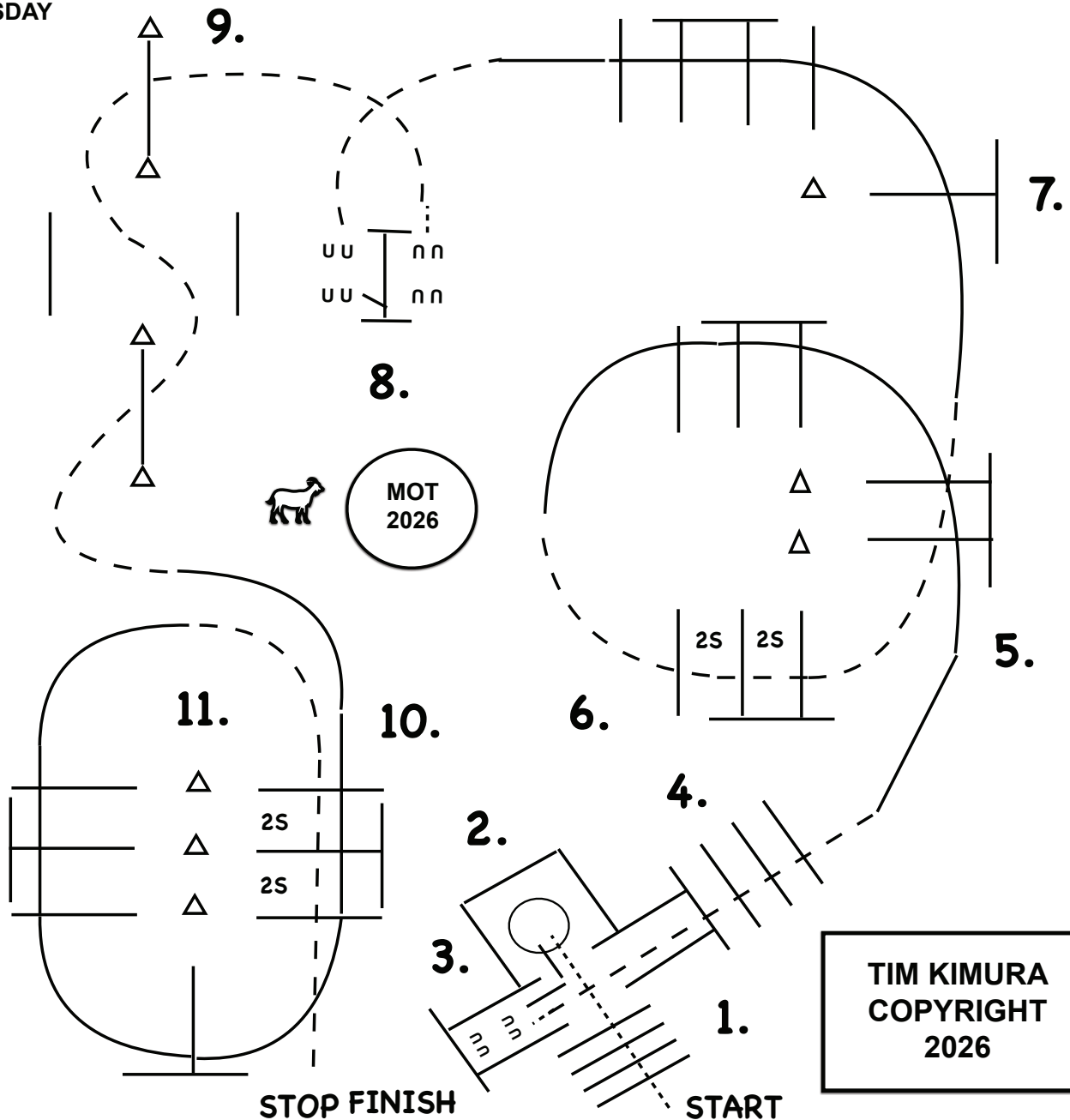

1. WALK OVER POLES, WALK INTO BOX.
2. EXECUTE A 360 TURN EITHER WAY.
3. BACK OUT BOX, BACK AROUND CORNER.
4. YOU MAY WALK FORWARD, THEN JOG OUT CHUTE, JOG OVER POLES.
5. LOPE OVER POLES (LEFT LEAD).
6. BREAK TO THE JOG, JOG OVER POLES.
7. LOPE OVER POLES (LEFT LEAD).
8. BREAK TO THE JOG, JOG UP TO GATE, WORK GATE LEFT HAND.
9. YOU MAY WALK FORWARD, THEN JOG THROUGH SERPENTINE JOG OVER POLES.
10. LOPE OVER POLES (RIGHT LEAD).
11. BREAK TO THE JOG, JOG OVER POLES AND STOP TO SHOW COMPLETION OF YOUR PATTERN.

L1 Youth, L1 Select, L1 Amateur, L1 Horse Non Pro Showmanship

Show Date: Thurs July 2

w w w . H o r s e S h o w P a t t e r n s . c o m

w w w . H o r s e S h o w P a t t e r n s . c o m

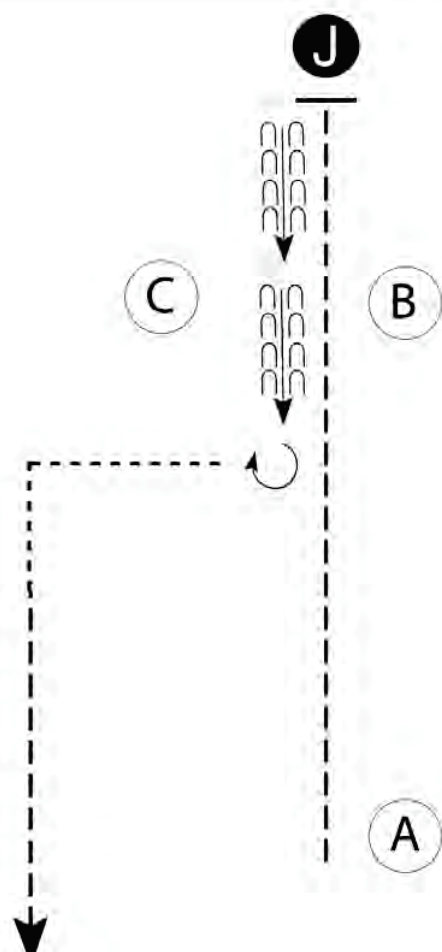

Be ready at A.

1. Trot to Judge.
2. Stop and set up for Inspection.
3. When dismissed, back through cones.
4. Perform a 270 degree turn.
5. Walk corner.
6. Trot to exit.
7. Pattern is complete once you pass start cone.

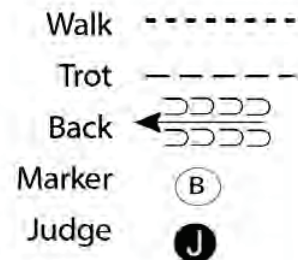

[S/3]

Pattern Provided by: *Judges*

Youth, Amateur, Select Showmanship

Show Date: Thurs July 2

w w w . H o r s e S h o w P a t t e r n s . c o m

w w w . H o r s e S h o w P a t t e r n s . c o m

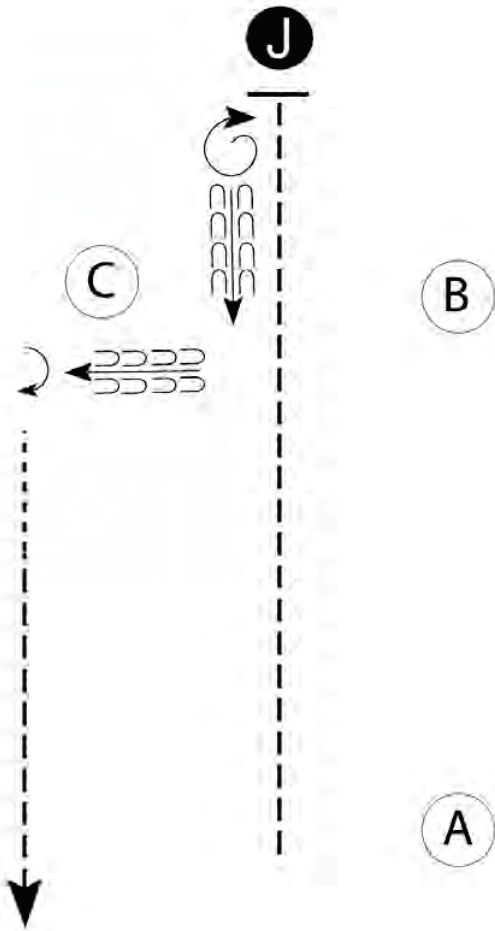

Be ready at A.

1. Trot to Judge.
2. Perform a 360 degree turn.
3. Set up for Inspection.
4. When dismissed, back L.
5. Perform a 90 degree turn.
6. Walk 2 horse lengths then trot to exit.
7. Pattern is complete once you trot past start cone.

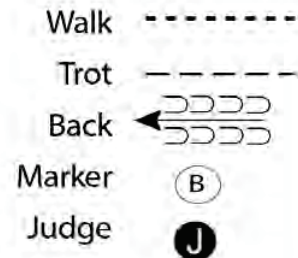

[S/1]

Pattern Provided by:
Judges

Western Riding L1 Open, L1 Youth, L1 Amateur

Show Date: Thurs July 2

w w w . H o r s e S h o w P a t t e r n s . c o m

w w w . H o r s e S h o w P a t t e r n s . c o m

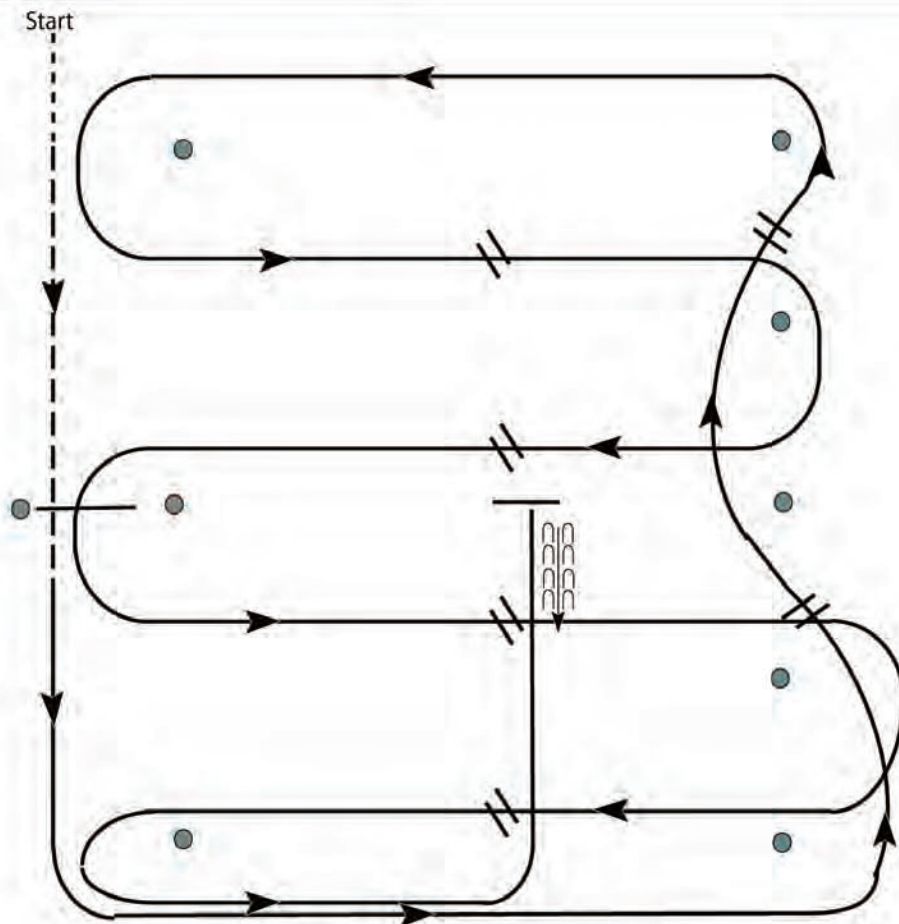

1. Walk at least 15' & jog over log.
2. Transition to left lead and lope around end.
3. First line change.
4. Second line change. Lope around end of arena
5. First crossing change.
6. Second crossing change.
7. Lope over log.
8. Third crossing change.
9. Fourth crossing change.
10. Lope up the center, stop and back.

[WR/GP-1]

Pattern Provided by:

The Judges

Western Riding Junior, Youth, Select, Amateur, Senior

Show Date: Thurs July 2

w w w . H o r s e S h o w P a t t e r n s . c o m

w w w . H o r s e S h o w P a t t e r n s . c o m

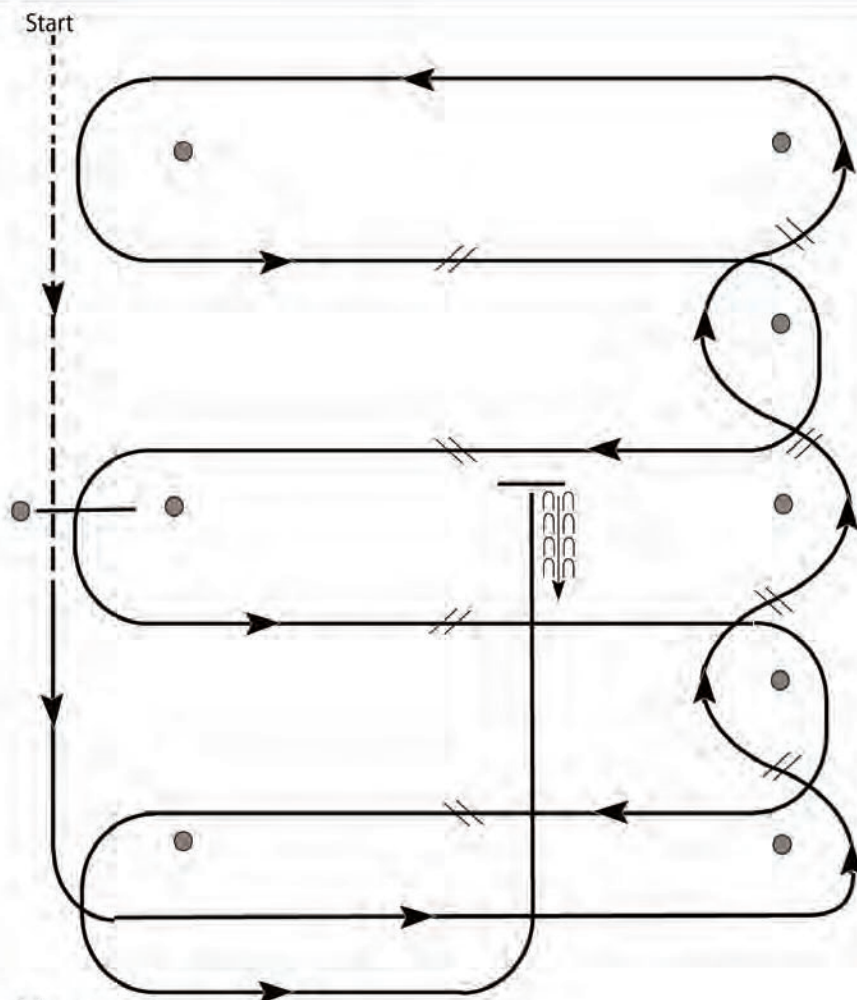

1. Walk and jog over log.
2. Transition to lope and lope around end.
3. First line change.
4. Second line change.
5. Third line change.
6. Fourth line change and lope around the end of the arena.
7. First crossing change.
8. Second crossing change.
9. Lope over log.
10. Third crossing change.
11. Fourth crossing change.
12. Lope up the center, stop and back.

[WR/OP-1]

Pattern Provided by:

The Judges

2026
The Celebration

**L1 TRAIL, L1 AMATEUR,
L1 YOUTH, AND JUNIOR TRAIL**

THURSDAY

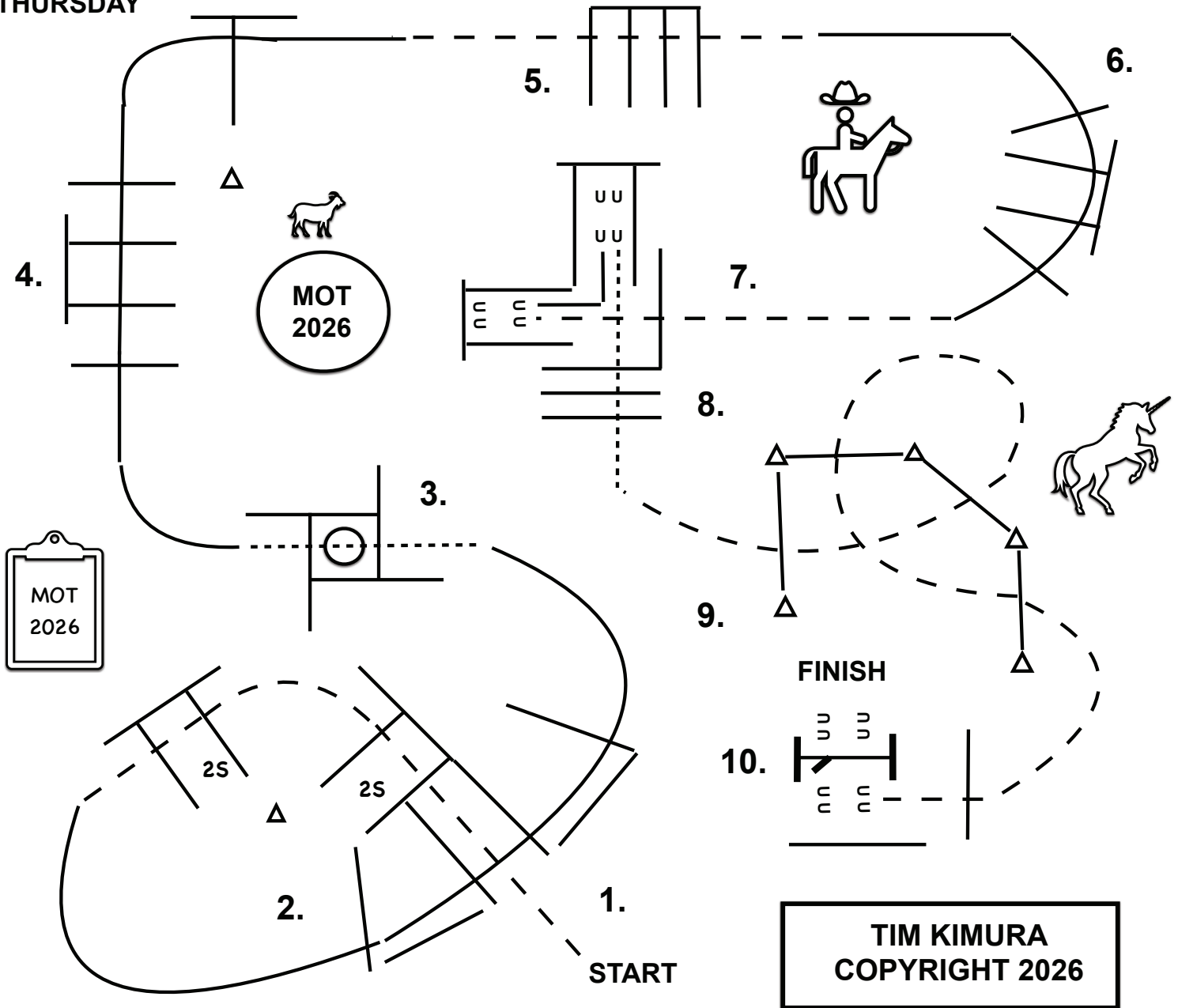

1. JOG OVER POLES.
2. LOPE OVER POLES (LEFT LEAD).
3. STOP OR BREAK TO THE WALK, WALK OVER POLE, WALK INTO BOX, EXECUTE A 360 TURN EITHER WAY, WALK OUT BOX, WALK OVER POLE.
4. LOPE OVER POLES (RIGHT LEAD).
5. BREAK TO THE JOG, JOG OVER POLES.
6. LOPE OVER POLES (RIGHT LEAD).
7. JOG OVER POLE, JOG INTO CHUTE, BACK BETWEEN POLES AND AROUND CORNER.
8. WALK OUT CHUTE, WALK OVER POLES.
9. JOG THROUGH SERPENTINE, JOG OVER POLES.
10. JOG OVER POLE, JOG UP TO GATE, WORK GATE RIGHT HAND.

2026
The Celebration

ALL WALK/TROT
TRAIL CLASSES

THURSDAY

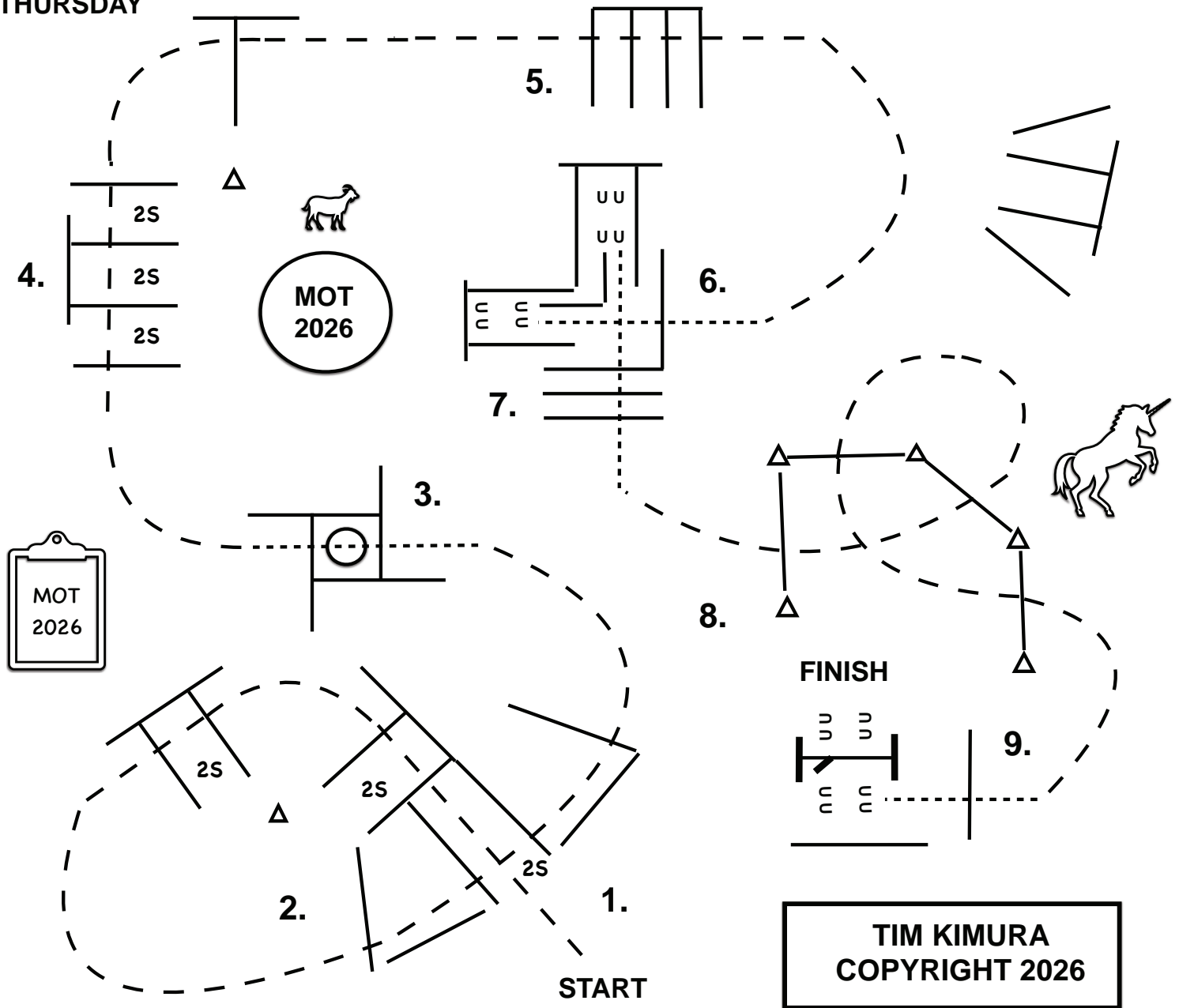

1. JOG OVER POLES.
2. JOG OVER POLES.
3. STOP OR BREAK TO THE WALK, WALK OVER POLE, WALK INTO BOX, EXECUTE A 360 TURN EITHER WAY, WALK OUT BOX, WALK OVER POLE.
4. JOG OVER POLES.
5. BREAK TO THE JOG, JOG OVER POLES.
6. STOP OR BREAK TO THE WALK, WALK INTO CHUTE, BACK BETWEEN POLES AND BACK AROUND CORNER.
7. WALK OUT CHUTE, WALK OVER POLES.
8. JOG THROUGH SERPENTINE, JOG OVER POLES.
9. STOP OR BREAK TO THE WALK, WALK OVER POLE, WALK UP TO GATE, WORK GATE RIGHT HAND.

TIM KIMURA
COPYRIGHT 2026

Walk/Trot

Horsemanship

Show Date: Fri July 3

w w w . H o r s e S h o w P a t t e r n s . c o m

w w w . H o r s e S h o w P a t t e r n s . c o m

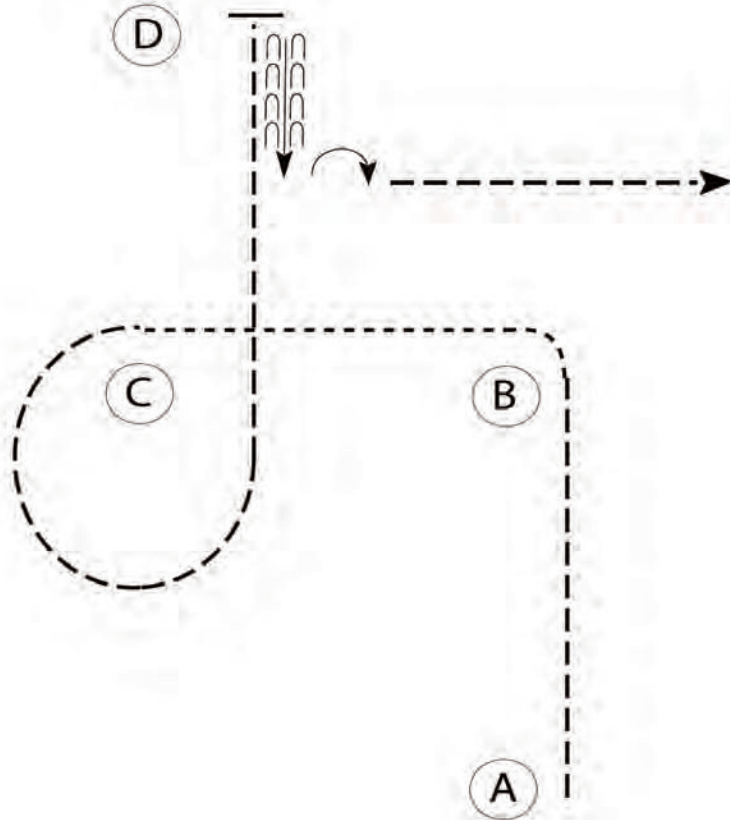

Be ready at A.

1. Jog to B.
2. Walk around B to the left and to C.
3. Jog at C around to D.
4. Stop and D and back approximately one horse length.
5. Turn 90 degrees to the right on the hindquarters and jog out.

Follow the directions of your ring steward.

Walk	-----
Jog	-----
Extended Jog	-----
Lope	-----
Lead Change	-----
Back	←-----
Marker	(B)

[WH/WT-78]

Pattern Provided by:

The Judges

L1 Youth, L1 Amateur, L1 Select, L1 Horse Non Pro Horsemanship

Show Date: Fri July 3

www.HorseShowPatterns.com

Be ready at A.

1. Jog to and around B.
2. Lope on the left lead from B to and around C.
3. Extended jog from C to D.
4. Stop at D and back approximately one horse length.
5. Turn 90 degrees to the right on the hindquarters and walk out.

Follow the directions of your ring steward.

Walk	-----
Jog	-----
Extended Jog	-----
Lope	-----
Lead Change	↘
Back	←
Marker	⊙ B

www.HorseShowPatterns.com

[WH/2-78]

Pattern Provided by:
The Judges

Youth, Amateur Select Horsemanship

Show Date: Fri July 3

w w w . H o r s e S h o w P a t t e r n s . c o m

w w w . H o r s e S h o w P a t t e r n s . c o m

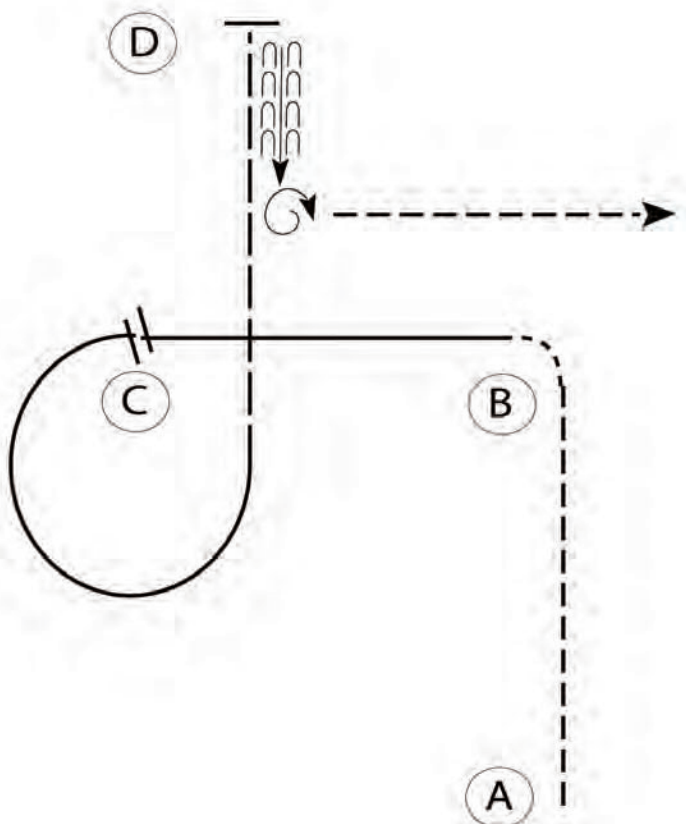

Be ready at A.

1. Jog to B.
2. Walk around B.
3. Lope on the right lead from B to C.
4. Perform a simple lead change at C.
5. Lope on the left lead around C.
6. Extended jog from C to D.
7. Stop at D and back approximately one horse length.
8. Spin 1 1/4 turns to the right on the hindquarters and jog out.

Walk	-----
Jog	-----
Extended Jog	-----
Lope	-----
Lead Change	-----
Back	←-----
Marker	(B)

Follow the directions of your ring steward.

[WH/3-78]

Pattern Provided by:
The Judges

Walk / Trot EQUITATION

Show Dates: Fri July 3

www.HorseShowPatterns.com

www.HorseShowPatterns.com

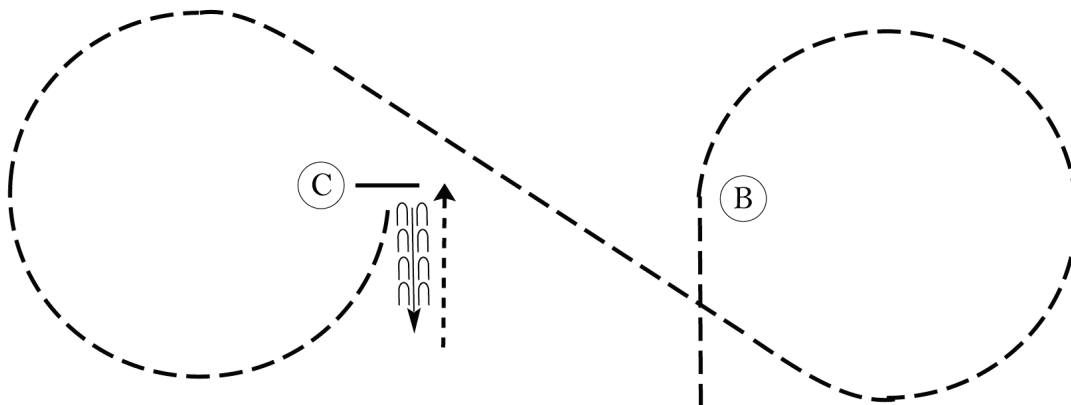

Be ready before A.

1. Walk to A.
2. Sitting trot to B.
3. At B, trot a circle to the right on the left diagonal.
4. When halfway to C, change diagonals.
5. Posting trot on the right diagonal to and around C.
6. Stop at C and back approximately one horse length.

Exit at a walk.

Follow the instructions of your ring steward.

Walk	-----
Trot	-----
Extended Trot	-----
Canter	-----
Leg Yield	
Lead Change	↘↘↘
Back	←←←
Marker	⊙ B
Sidepass	←←←
Hand Gallop	-----

[HSE/WT-41]

Pattern Provided by:

JUDGES

LEVEL 1 EQUITATION

Fri July 3

w w w . H o r s e S h o w P a t t e r n s . c o m

w w w . H o r s e S h o w P a t t e r n s . c o m

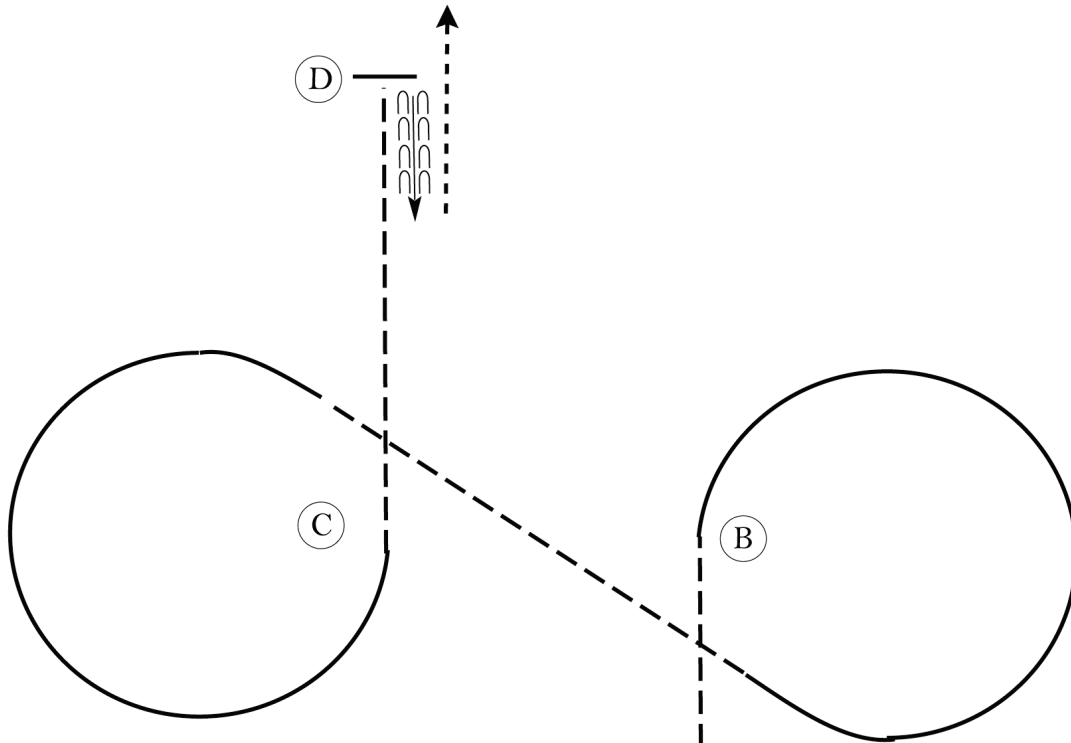

Be ready before A.

1. Walk to A.
2. Posting trot on the left diagonal to B.
3. At B, canter a circle to the right.
4. When even with B, sitting trot to C.
5. At C, canter a circle to the left.
6. Posting trot on the right diagonal from C to D.
7. Stop at D and back approximately one horse length.

Exit at a walk.

Follow the instructions of your ring steward.

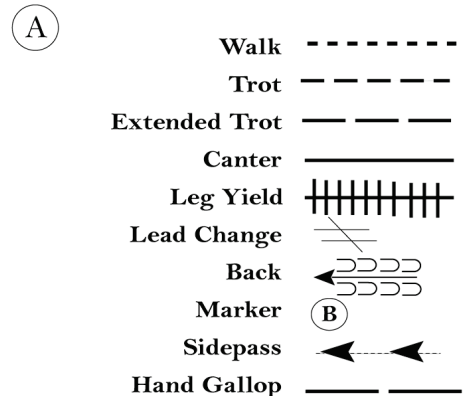

[HSE/1-41]

Pattern Provided by:

JUDGES

YTH, SELECT & AM EQUITATION

Fri July 3

www.HorseShowPatterns.com

www.HorseShowPatterns.com

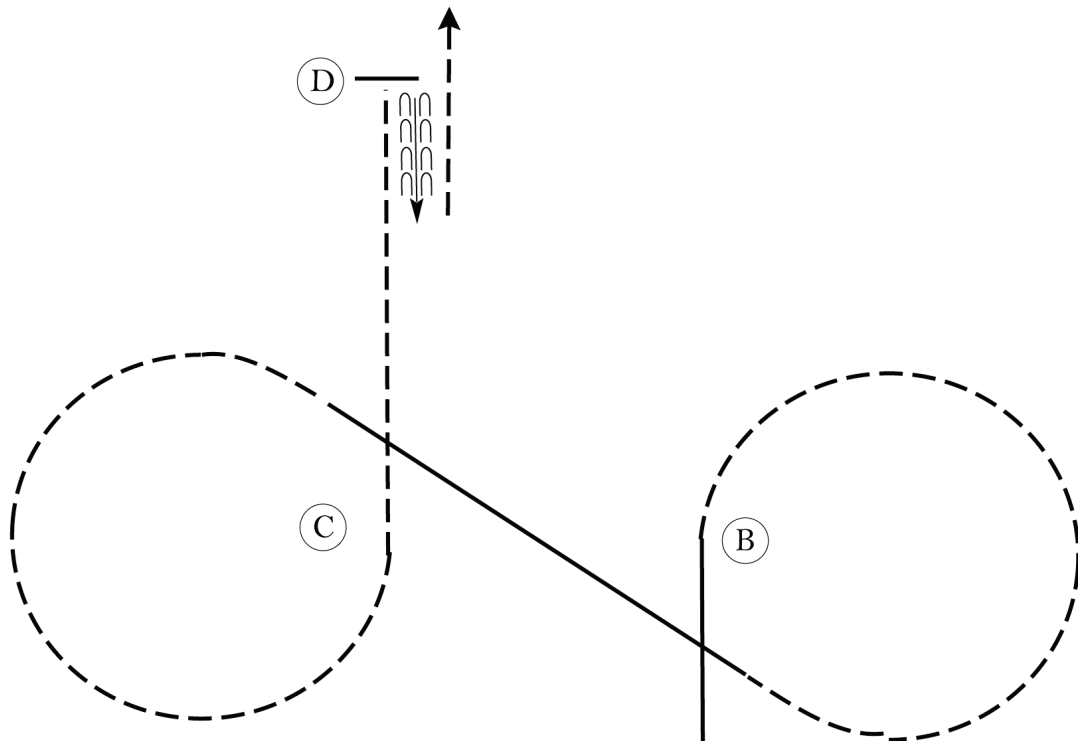

Be ready before A.

1. Walk to A.
2. Canter on the right lead to B.
3. Posting trot a circle to the right on the left diagonal.
4. When even with B, canter on the left lead to C.
5. At C, posting trot a circle to the left on the right diagonal.
6. Sitting trot from C to D.
7. Stop at D and back approximately one horse length.

Exit at a sitting trot.

Follow the instructions of your ring steward.

Walk	-----
Trot	- - - - -
Extended Trot	— — — — —
Canter	— — — — —
Leg Yield	
Lead Change	— / —
Back	← ← ← ← ←
Marker	(B)
Sidepass	← - - - - ←
Hand Gallop	— — — — —

[HSE/2-41]

Pattern Provided by:
JUDGES

**2026
The Celebration**

**YOUTH AND SENIOR TRAIL
SELECT AND AMATEUR TRAIL**

FRIDAY

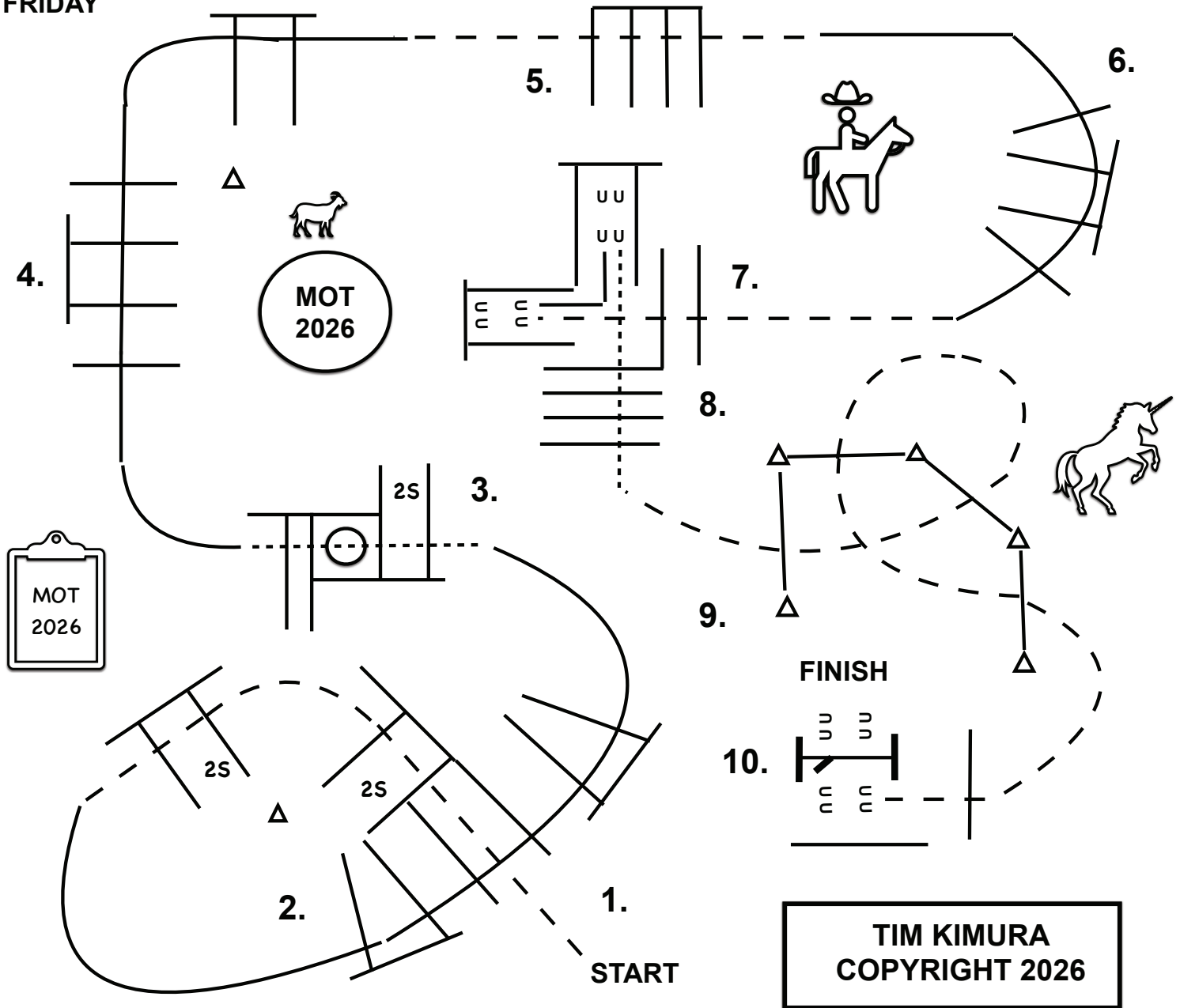

**TIM KIMURA
COPYRIGHT 2026**

1. JOG OVER POLES.
2. LOPE OVER POLES (LEFT LEAD).
3. STOP OR BREAK TO THE WALK, WALK OVER POLES, WALK INTO BOX, EXECUTE A 360 TURN EITHER WAY, WALK OUT BOX, WALK OVER POLES.
4. LOPE OVER POLES (RIGHT LEAD).
5. BREAK TO THE JOG, JOG OVER POLES.
6. LOPE OVER POLES (RIGHT LEAD).
7. JOG OVER POLES, JOG INTO CHUTE, BACK BETWEEN POLES AND AROUND CORNER.
8. WALK OUT CHUTE, WALK OVER POLES.
9. JOG THROUGH SERPENTINE, JOG OVER POLES.
10. JOG OVER POLE, JOG UP TO GATE, WORK GATE RIGHT HAND.

Showmanship

Walk Trot - Saturday July 4

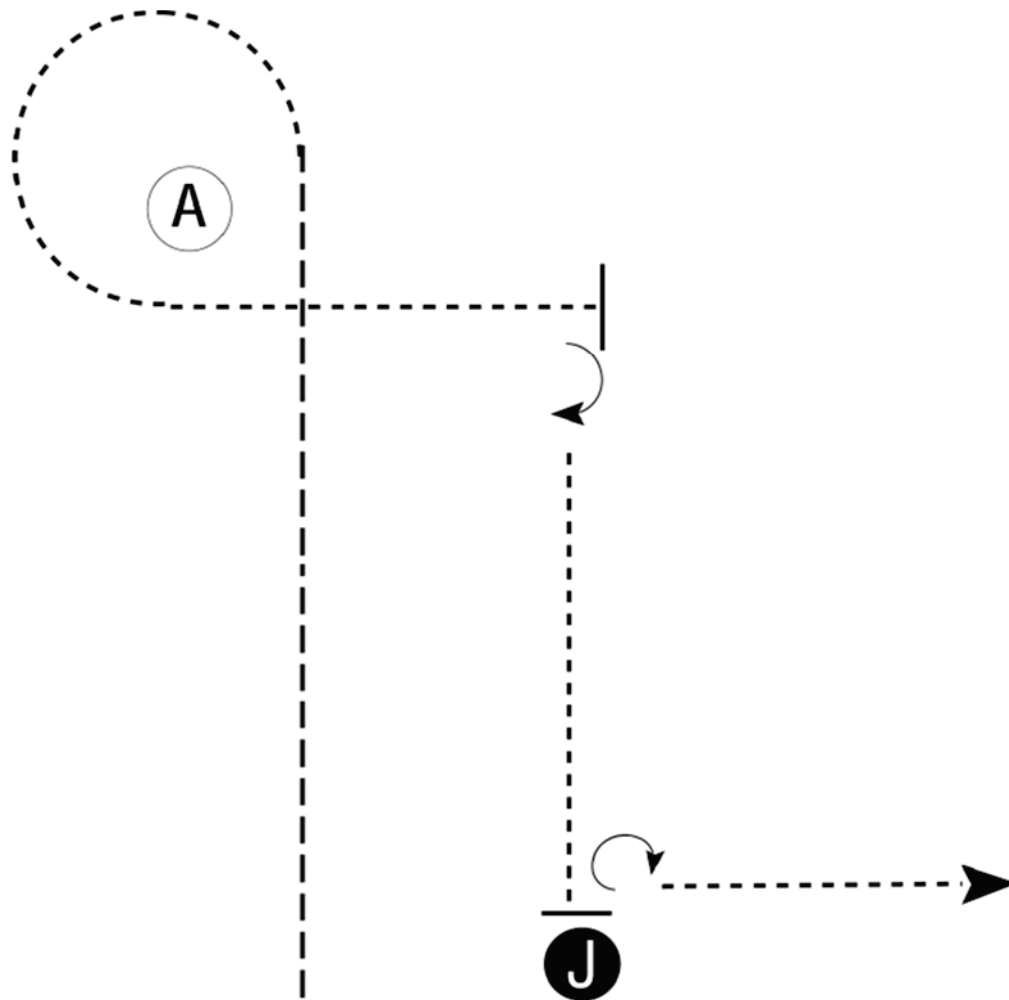

Be ready even with the judge.

1. Trot to A.
2. Walk around A until even with judge, stop.
3. Perform a 90 degree turn.
4. Walk to judge, stop.
5. Set up for inspection.
6. Inspection.
7. When dismissed, perform a 270 degree turn and walk straight away.

Walk	-----
Trot	-----
Back	← ↗ ↘ ↗ ↘
Marker	Ⓟ
Judge	●

Showmanship

All Level 1 - Saturday July 4

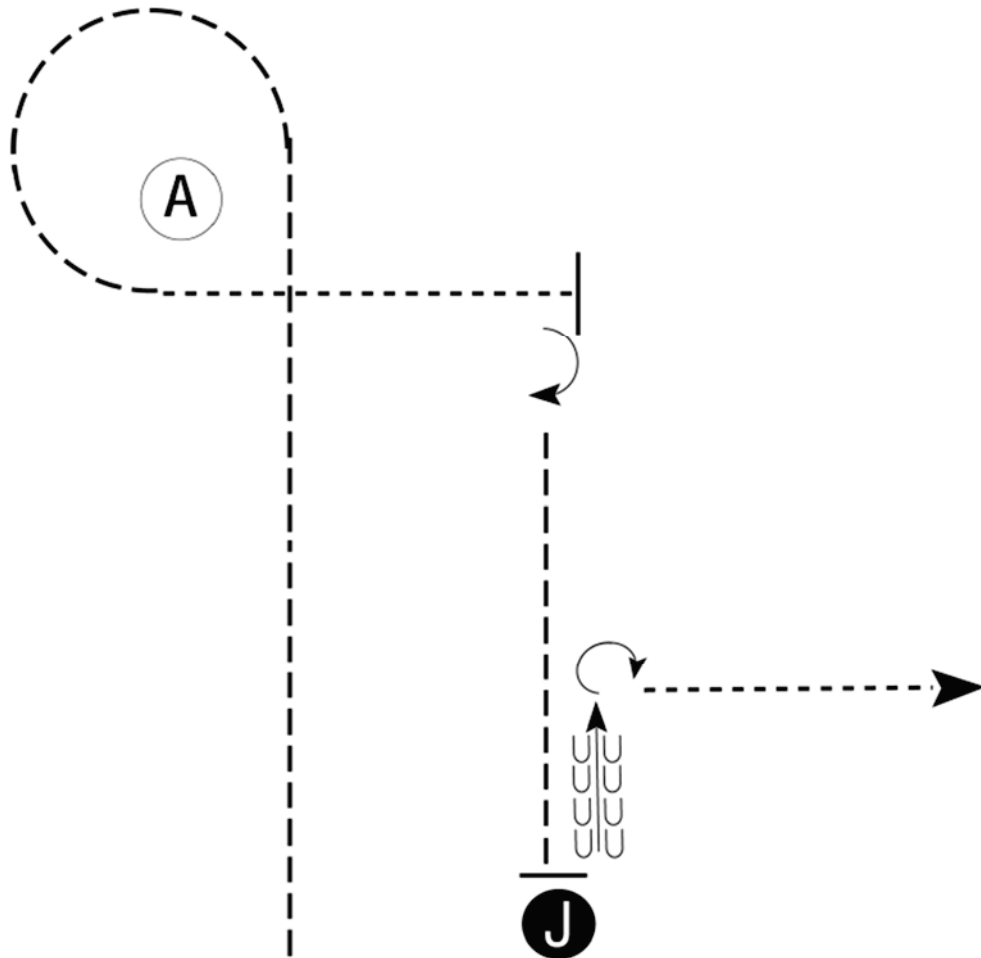

Be ready even with the judge.

1. Trot to and around A.
2. Walk from A until even with judge, stop.
3. Perform a 90 degree turn.
4. Trot to judge, stop.
5. Set up for inspection.
6. Inspection.
7. When dismissed, back one horse length
8. Perform a 270 degree turn and walk straight away.

Walk	-----
Trot	- - - - -
Back	← 
Marker	ⓑ
Judge	ⓐ

Showmanship

Youth/Amateur/Select - Saturday July 4

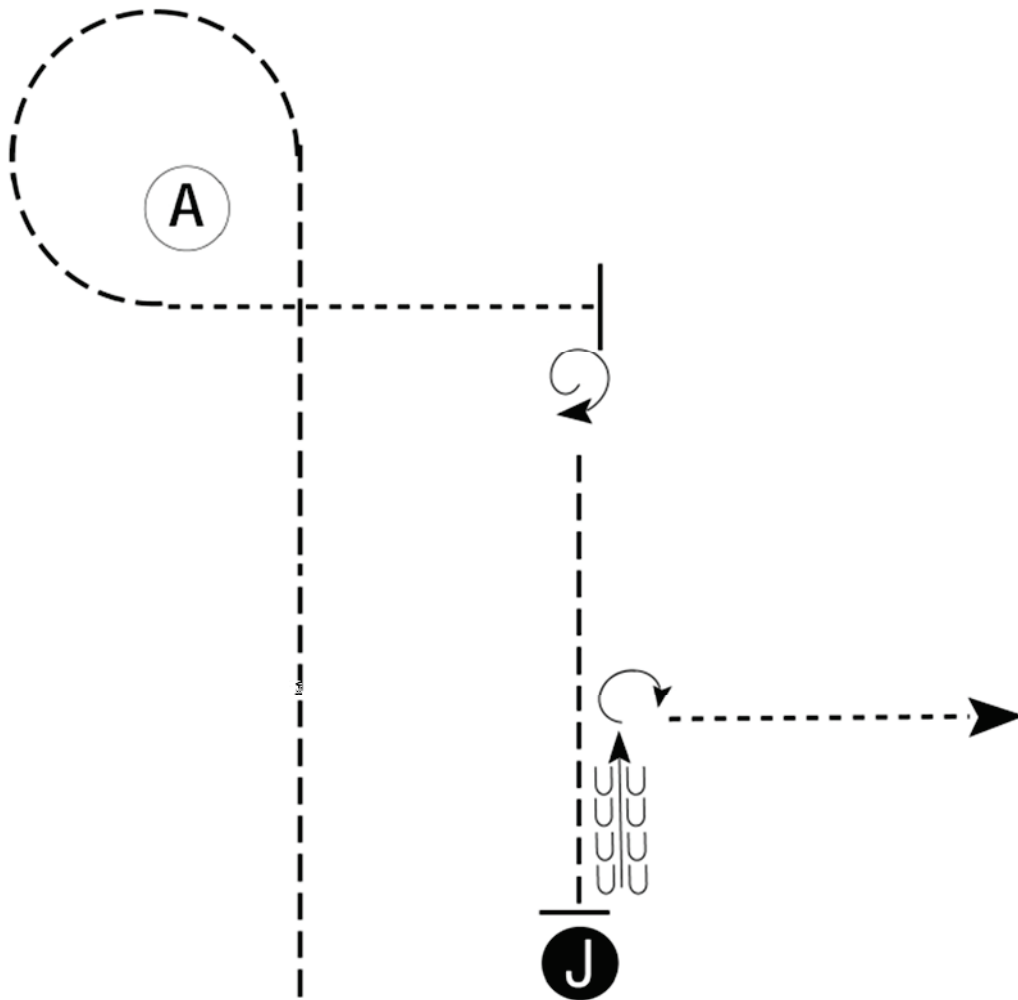

Be ready even with the judge.

1. Trot to and around A.
2. Walk to A until even with judge, stop.
3. Perform a 450 degree turn.
4. Trot to judge, stop.
5. Set up for inspection.
6. Inspection.
7. When dismissed, back one horse length
8. Perform a 270 degree turn and walk straight away.

Walk
Trot	- - - - -
Back	← ←
Marker	ⓐ
Judge	●

Western Riding (L1 Yth, L1 Am and L1 Open)

Show Date: Sat July 4

www.HorseShowPatterns.com

www.HorseShowPatterns.com

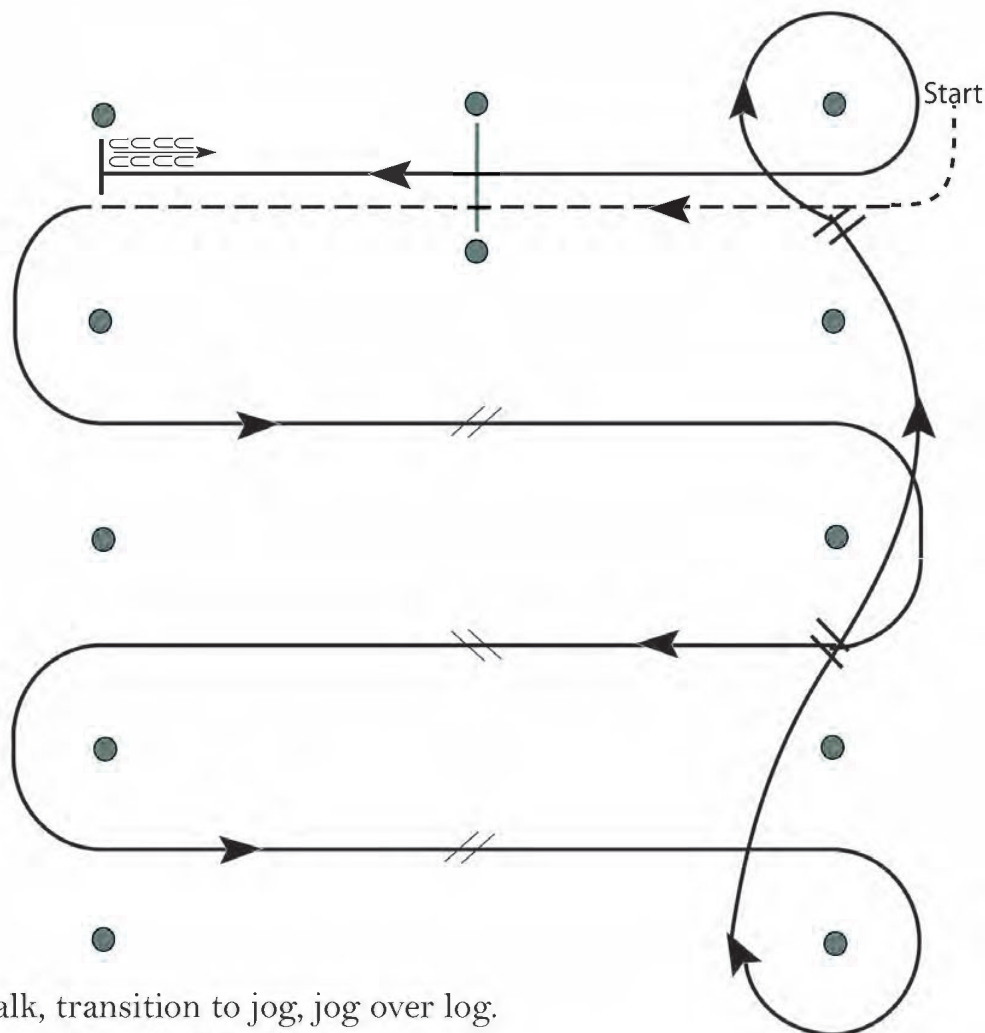

1. Walk, transition to jog, jog over log.
2. Transition to left lead lope.
3. First crossing change.
4. Second crossing change.
5. Third crossing change.
6. Circle and first line change.
7. Second line change and circle.
8. Lope log.
9. Stop and back.

[WR/GP-2]

Pattern Provided by:

The Judges

Western Riding (Youth, Am, Select, Junior, Senior L2,L3)

Show Date: Sat July 4

w w w . H o r s e S h o w P a t t e r n s . c o m

w w w . H o r s e S h o w P a t t e r n s . c o m

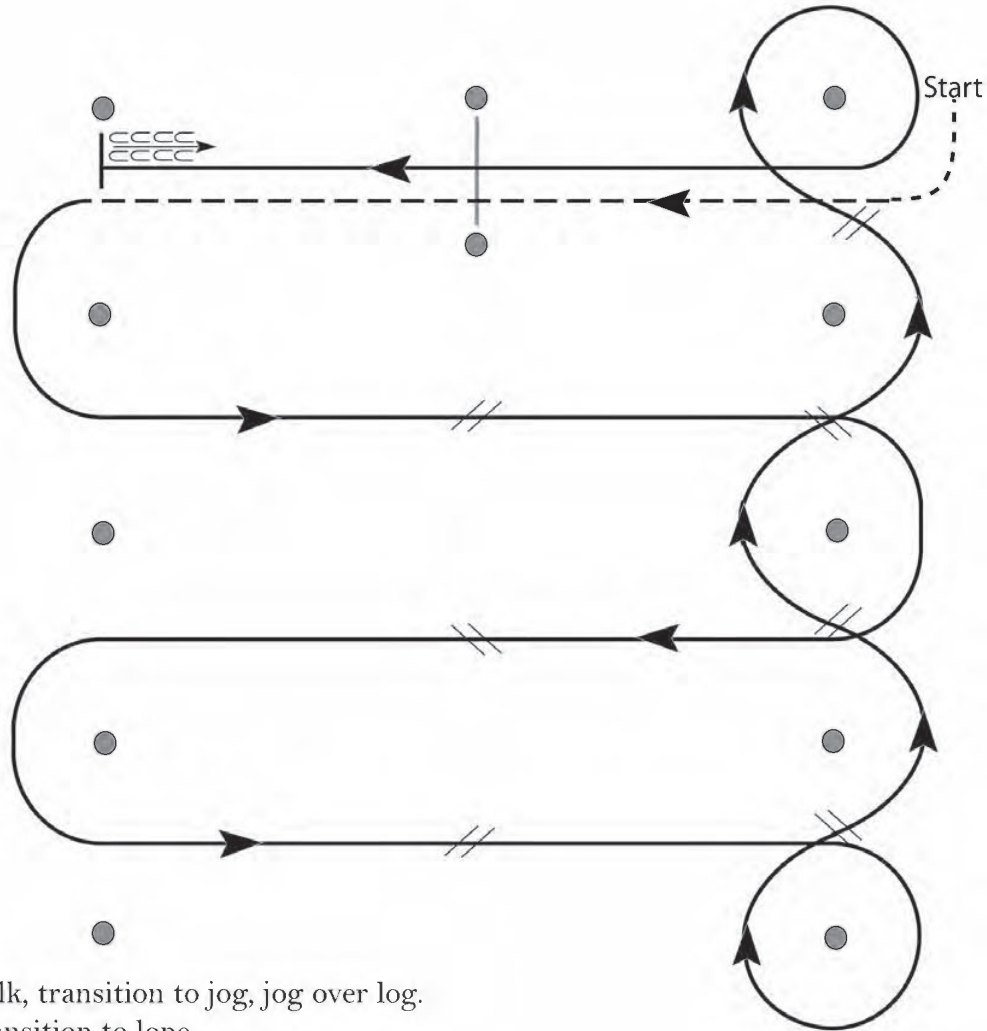

1. Walk, transition to jog, jog over log.
2. Transition to lope.
3. First crossing change.
4. Second crossing change.
5. Third crossing change.
6. Circle and first line change.
7. Second line change.
8. Third line change.
9. Fourth line change and circle.
10. Lope log.
11. Lope, stop and back.

[WR/OP-2]

Pattern Provided by:

The Judges

SATURDAY



TIM KIMURA
COPYRIGHT
2026

MOT
2026

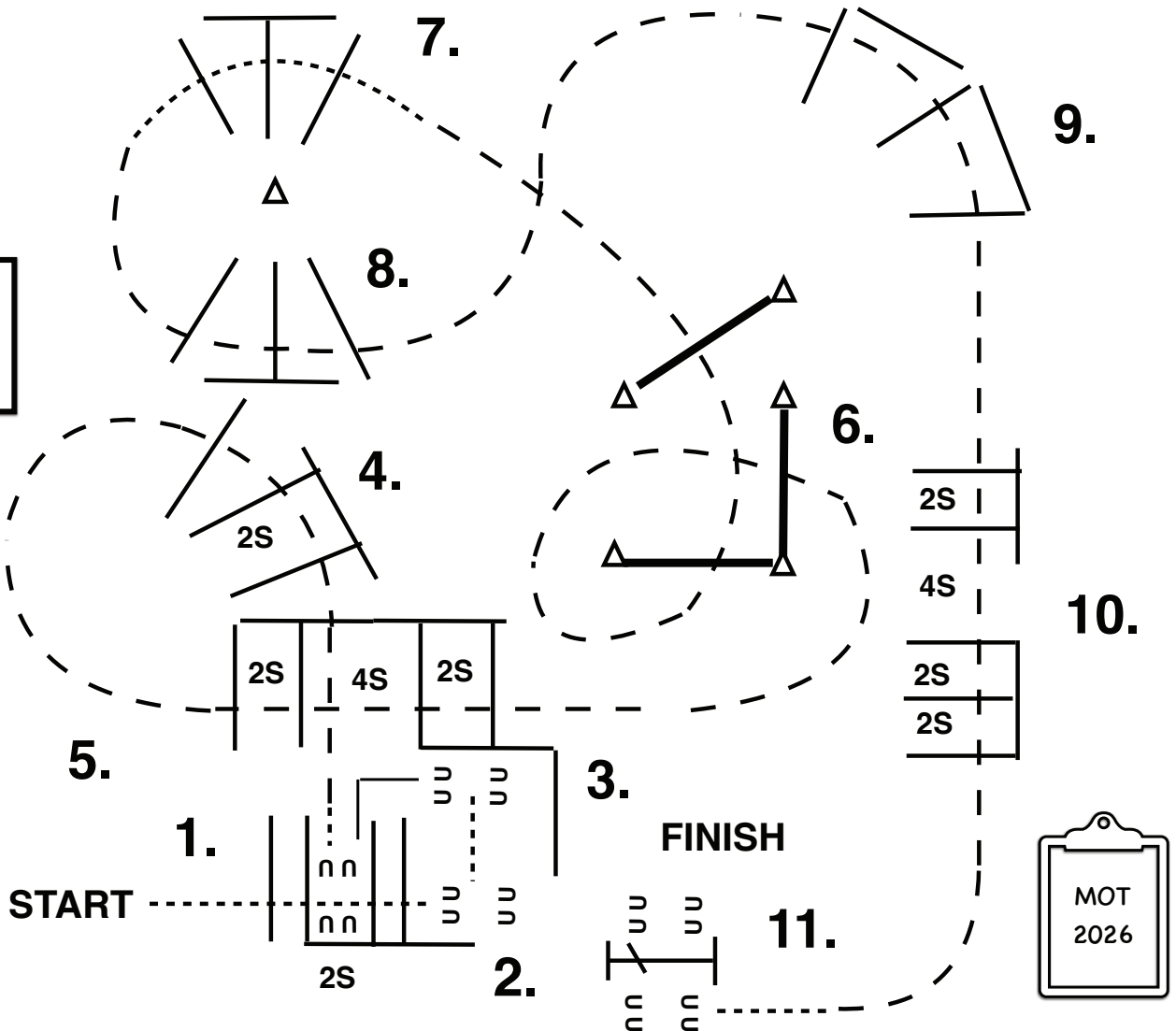

1. WALK OVER POLES.
2. SIDE PASS LEFT BETWEEN POLES.
3. BACK AROUND CORNER, BACK BETWEEN POLES.
4. YOU MAY WALK FORWARD, THEN JOG OVER POLES.
5. JOG OVER POLES.
6. JOG THROUGH SERPENTINE, JOG OVER POLES.
7. STOP OR BREAK TO THE WALK, WALK OVER POLES.
8. JOG OVER POLES.
9. JOG OVER POLES.
10. JOG OVER POLES.
11. STOP OR BREAK TO THE WALK, WALK UP TO GATE, WORK GATE RIGHT HAND.

2026
The Celebration

L1 TRAIL, L1 AMATEUR,
L1 YOUTH, AND JUNIOR TRAIL

SATURDAY



TIM KIMURA
COPYRIGHT
2026

MOT
2026

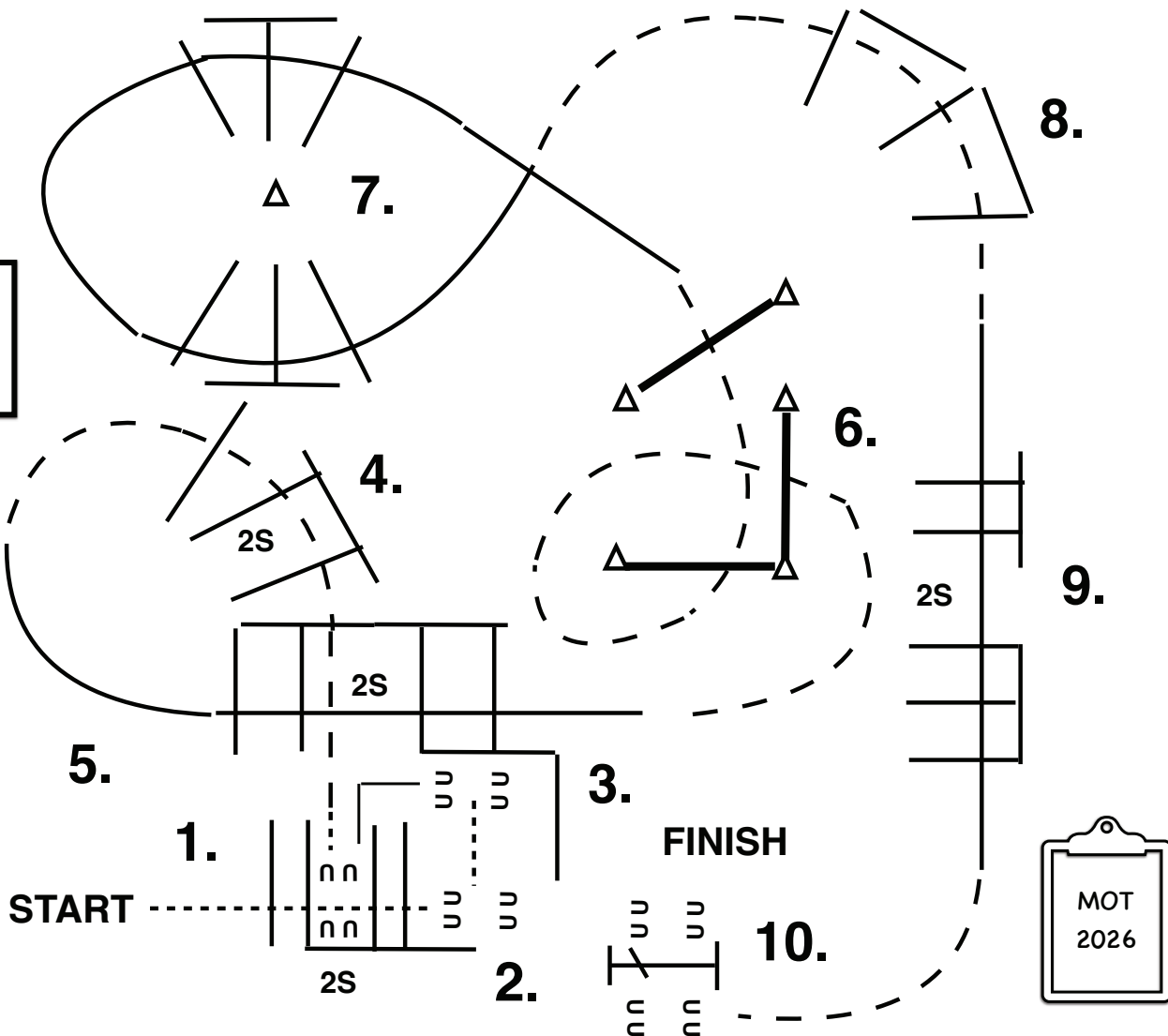

1. WALK OVER POLES.
2. SIDE PASS LEFT BETWEEN POLES.
3. BACK AROUND CORNER, BACK BETWEEN POLES.
4. YOU MAY WALK FORWARD, THEN JOG OVER POLES.
5. LOPE OVER POLES (LEFT LEAD).
6. BREAK TO THE JOG, JOG THROUGH SERPENTINE, JOG OVER POLES.
7. LOPE OVER POLES (LEFT LEAD).
8. BREAK TO THE JOG, JOG OVER POLES.
9. LOPE OVER POLES (RIGHT LEAD).
10. BREAK TO THE JOG, JOG UP TO GATE, WORK GATE RIGHT HAND.

Horsemanship

Walk/Trot - Sun July 5

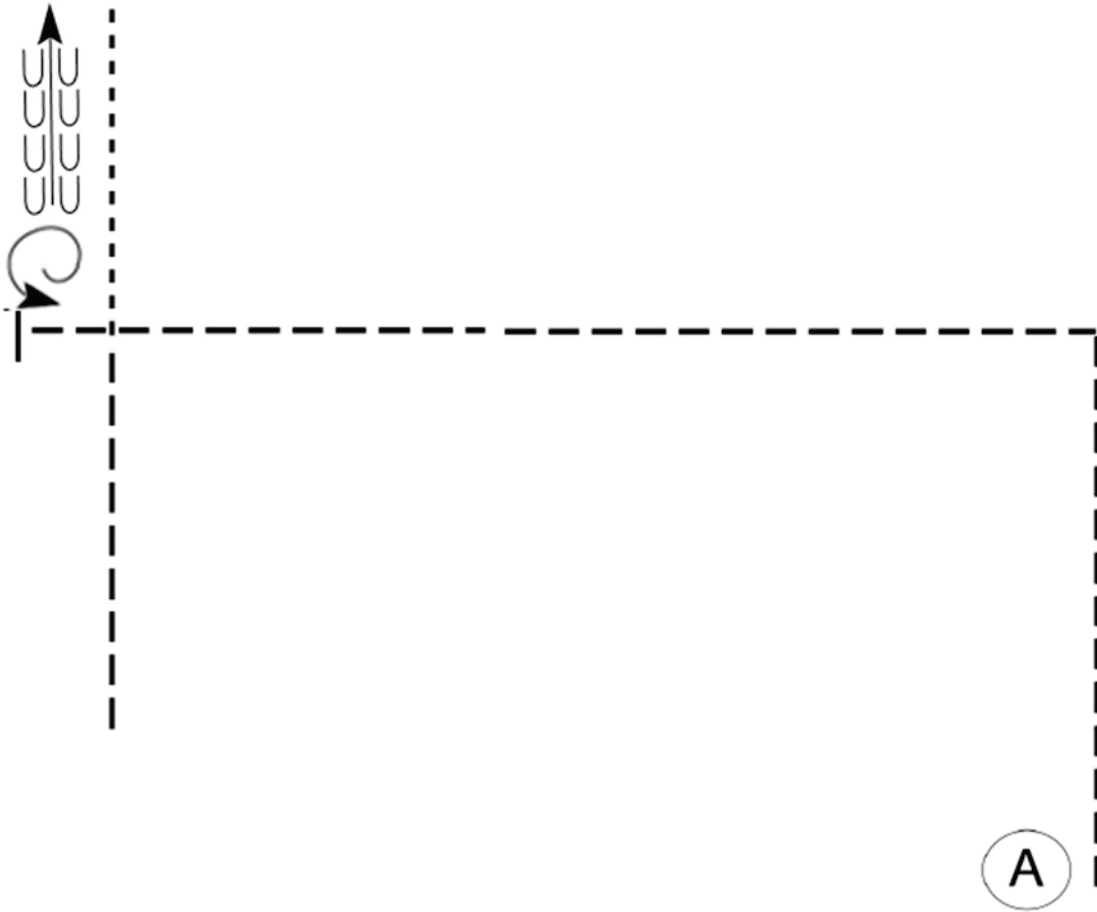

Be ready at A.

1. Extended jog from A and perform a square corner.
2. Slow to a jog and continue in a straight line.
3. Stop and perform a 1 ¼ turn left.
4. Back.
5. Walk until you cross your line then extended jog to exit.

Walk
Jog	-----
Extended Jog	————
Lope	————
Lead Change	
Back	
Marker	⊙ B

Horsemanship

All Level 1/Novice - Sun July 5

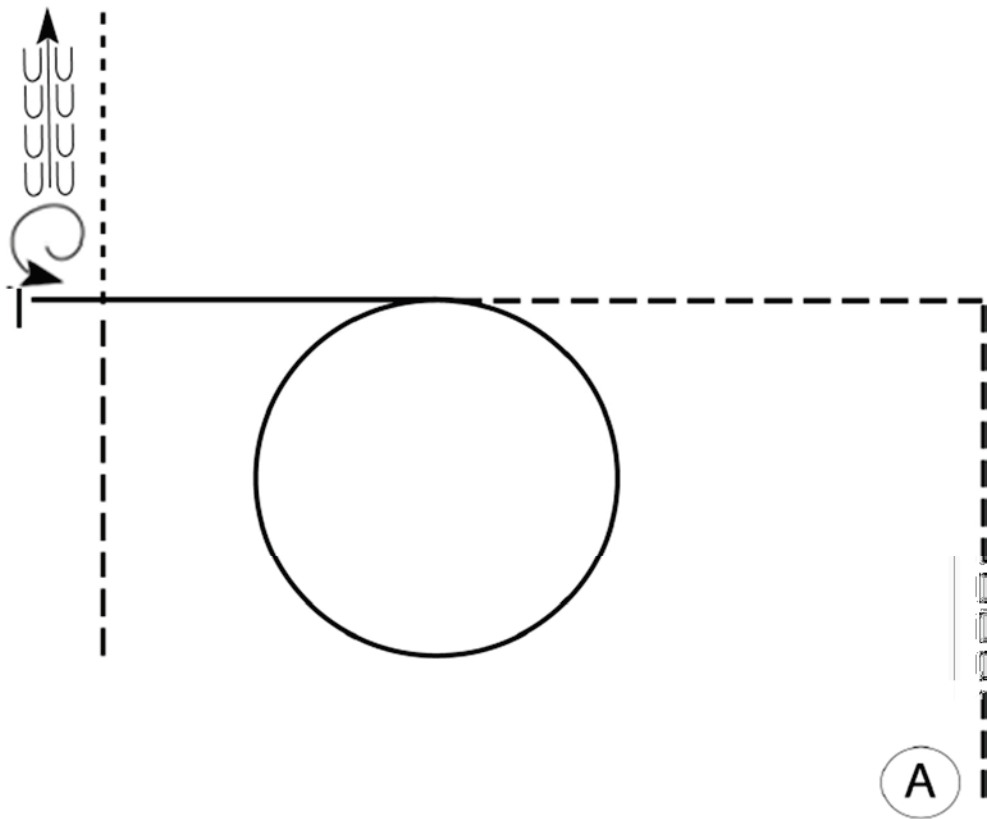

Be ready at A.

1. Extended jog from A and perform a square corner then slow to a jog to center of pattern.
2. Lope left lead circle.
3. Close the circle and continue loping in a straight line.
4. Stop and perform a 1 ¼ turn left.
5. Back.
6. Walk until you cross your line then extended jog to exit.

Walk
Jog	-----
Extended Jog	————
Lope	————
Lead Change	
Back	
Marker	ⓐ

Horsemanship

All Youth/Amateur - Sun July 5

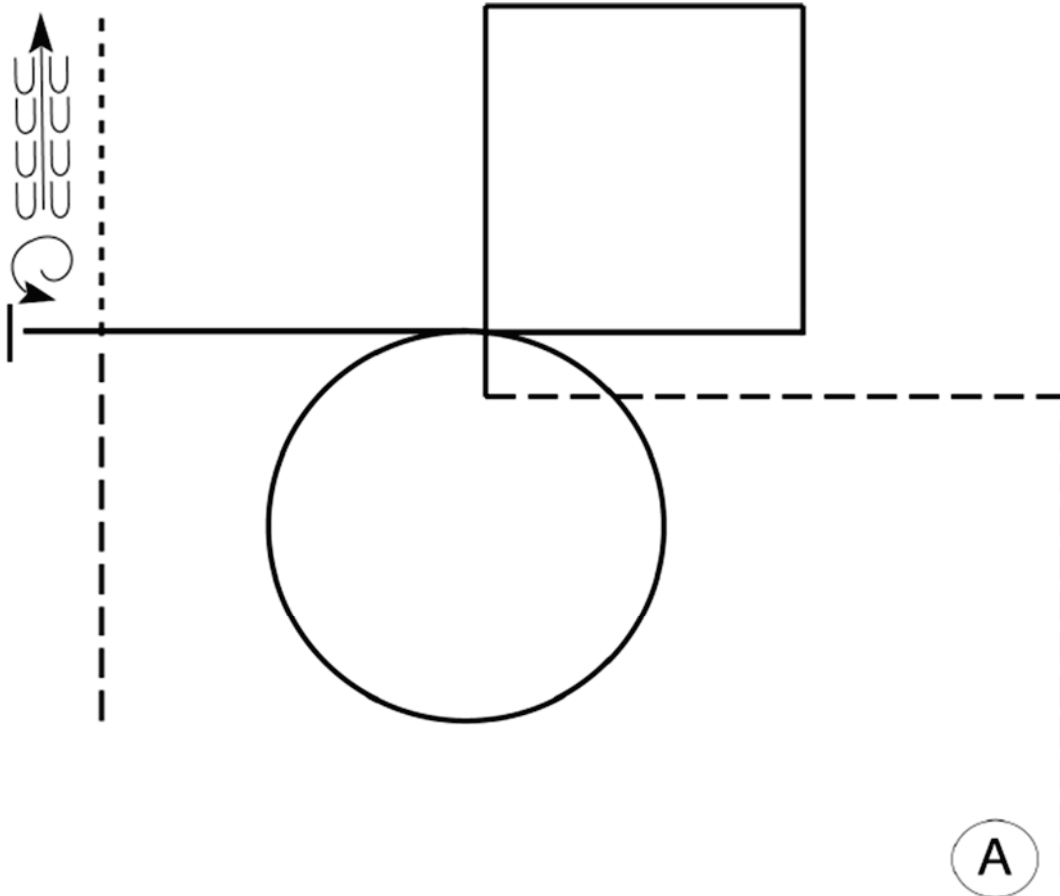

Be ready at A.

1. Extended jog from A and perform a square corner.
2. Slow to a jog and make a square corner at center of pattern.
3. Lope right lead square.
4. Change leads.
5. Lope a circle.
6. Close the circle and continue loping in a straight line.
7. Stop and perform 1 ¼ turn left.
8. Back.
9. Walk until you cross your line then extended jog to exit.

Walk	-----
Jog	-----
Extended Jog	-----
Lope	-----
Lead Change	
Back	
Marker	ⓐ

Hunt Seat Equitation

Walk/Trot - Sun July 5

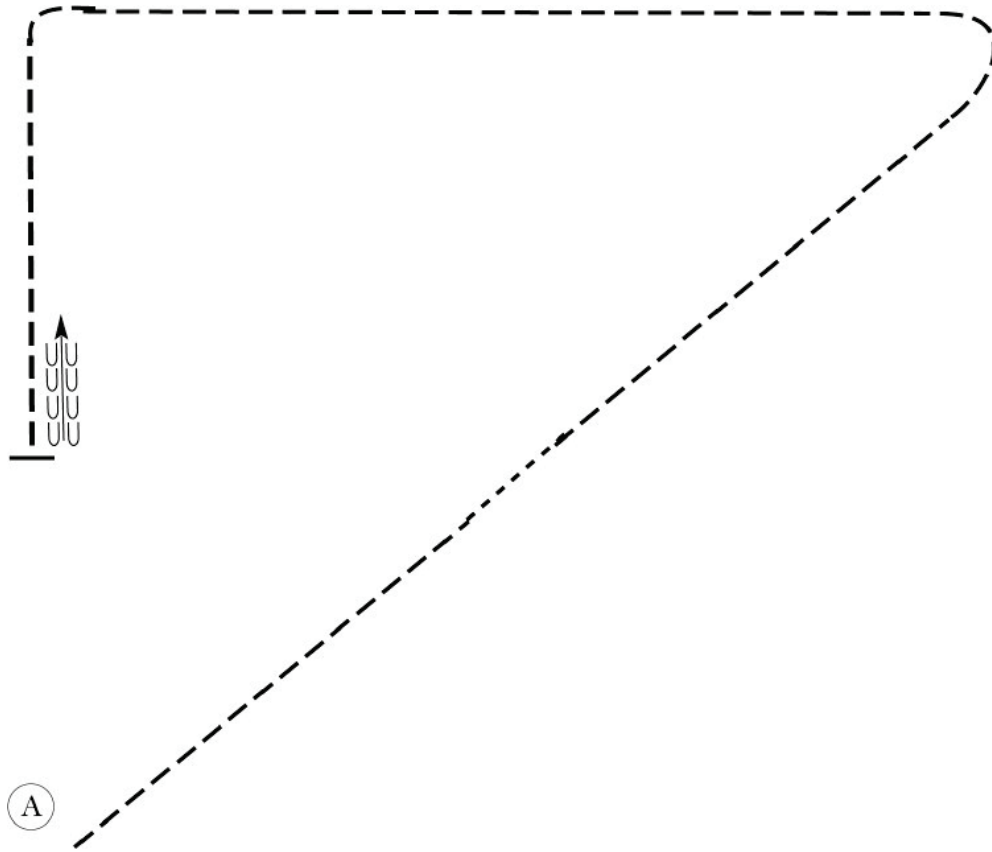

Be ready at A.

1. Trot Right Diagonal.
2. Walk 3 to 4 horse lengths.
3. Trot on the left diagonal to corner, change diagonals and trot to next corner.
4. At corner, perform a sitting trot halfway to A.
5. When halfway to A, stop and back.
Pattern is complete.

Trot to exit.

Walk	-----
Trot	- - - - -
Extended Trot	— — — — —
Canter	—————
Leg Yield	
Lead Change	— / —
Back	← ← ← ← ←
Marker	ⓑ
Sidepass	← ← ← ← ←
Hand Gallop	— — — — —

Hunt Seat Equitation

All Youth/Amateur - Sun July 5

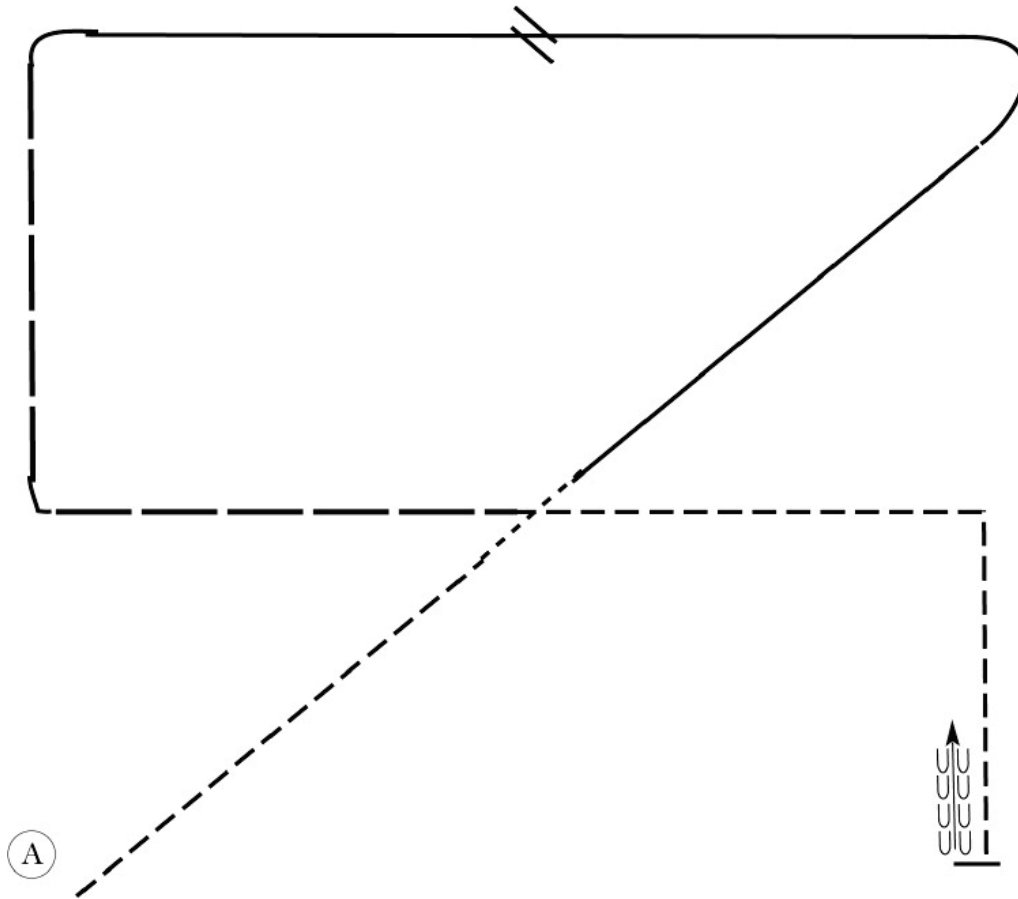

Be ready at A.

1. Trot Right Diagonal.
 2. Walk 3 to 4 horse lengths.
 3. Canter on the right lead.
 4. Change leads and continue to corner.
 5. Hand gallop, crossing over your line.
 6. Break to a trot remaining in the 2-point position.
 7. Left diagonal after your corner until you are in line with A.
 8. Stop and back.
- Pattern is complete.

Trot to exit.

Walk
Trot	-----
Extended Trot	-----
Canter	—————
Leg Yield	
Lead Change	///
Back	←←←←
Marker	ⓑ
Sidepass	←←←←
Hand Gallop	—————

2026
The Celebration

YOUTH AND SENIOR TRAIL
SELECT AND AMATEUR TRAIL

SUNDAY



TIM KIMURA
COPYRIGHT
2026

MOT
2026

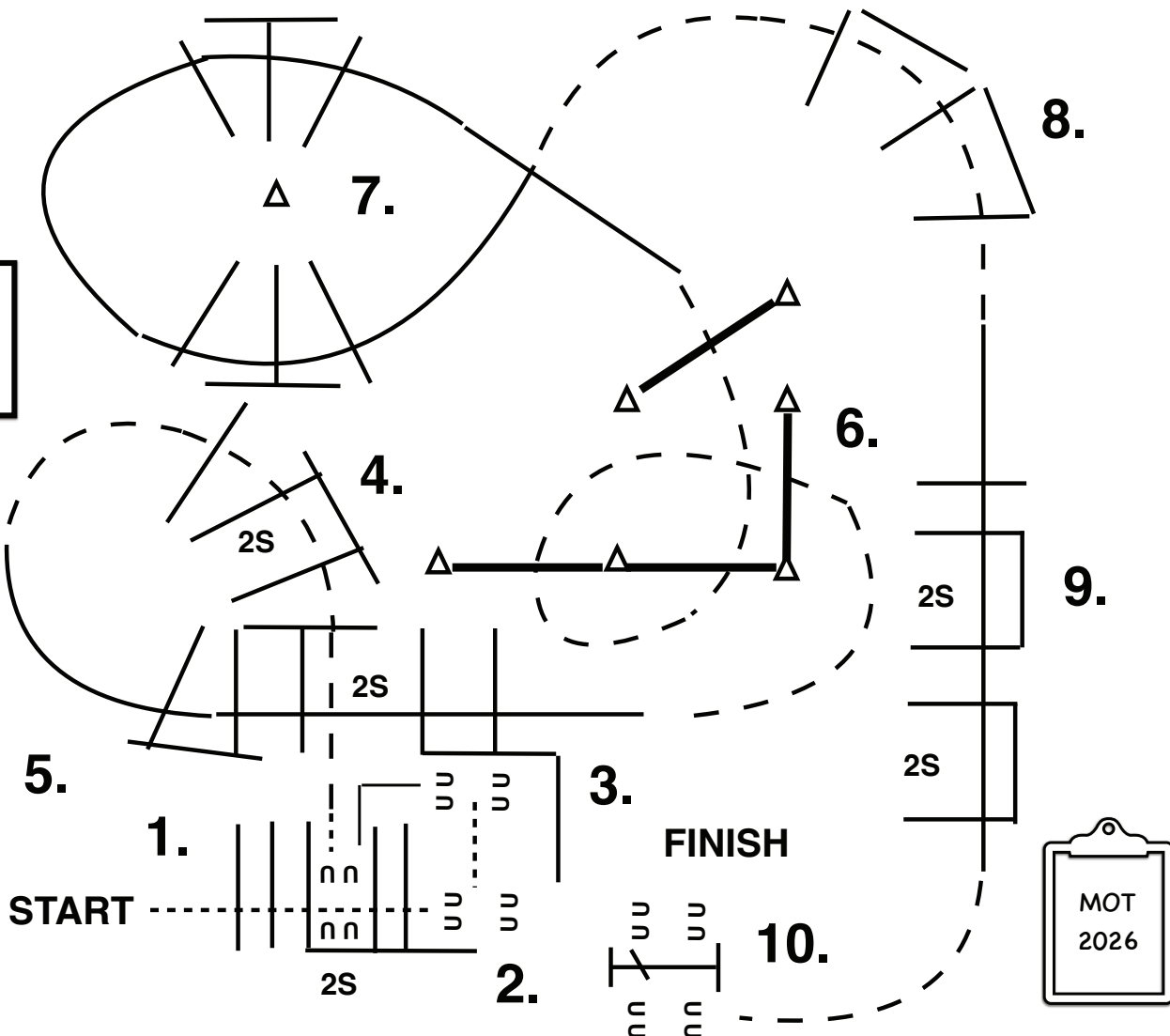

1. WALK OVER POLES.
2. SIDE PASS LEFT BETWEEN POLES.
3. BACK AROUND CORNER, BACK BETWEEN POLES.
4. YOU MAY WALK FORWARD, THEN JOG OVER POLES.
5. LOPE OVER POLES (LEFT LEAD).
6. BREAK TO THE JOG, JOG THROUGH SERPENTINE, JOG OVER POLES.
7. LOPE OVER POLES (LEFT LEAD).
8. BREAK TO THE JOG, JOG OVER POLES.
9. LOPE OVER POLES (RIGHT LEAD).
10. BREAK TO THE JOG, JOG UP TO GATE, WORK GATE RIGHT HAND.

WALK TROT RANCH RIDING - PATTERN 2

Friday June 26

LEGEND

- Walk
- Extended Walk
- - - Trot
- - - Extended Trot
- Lope
- Extended Lope
- ////// Back
- \\ Lead Change

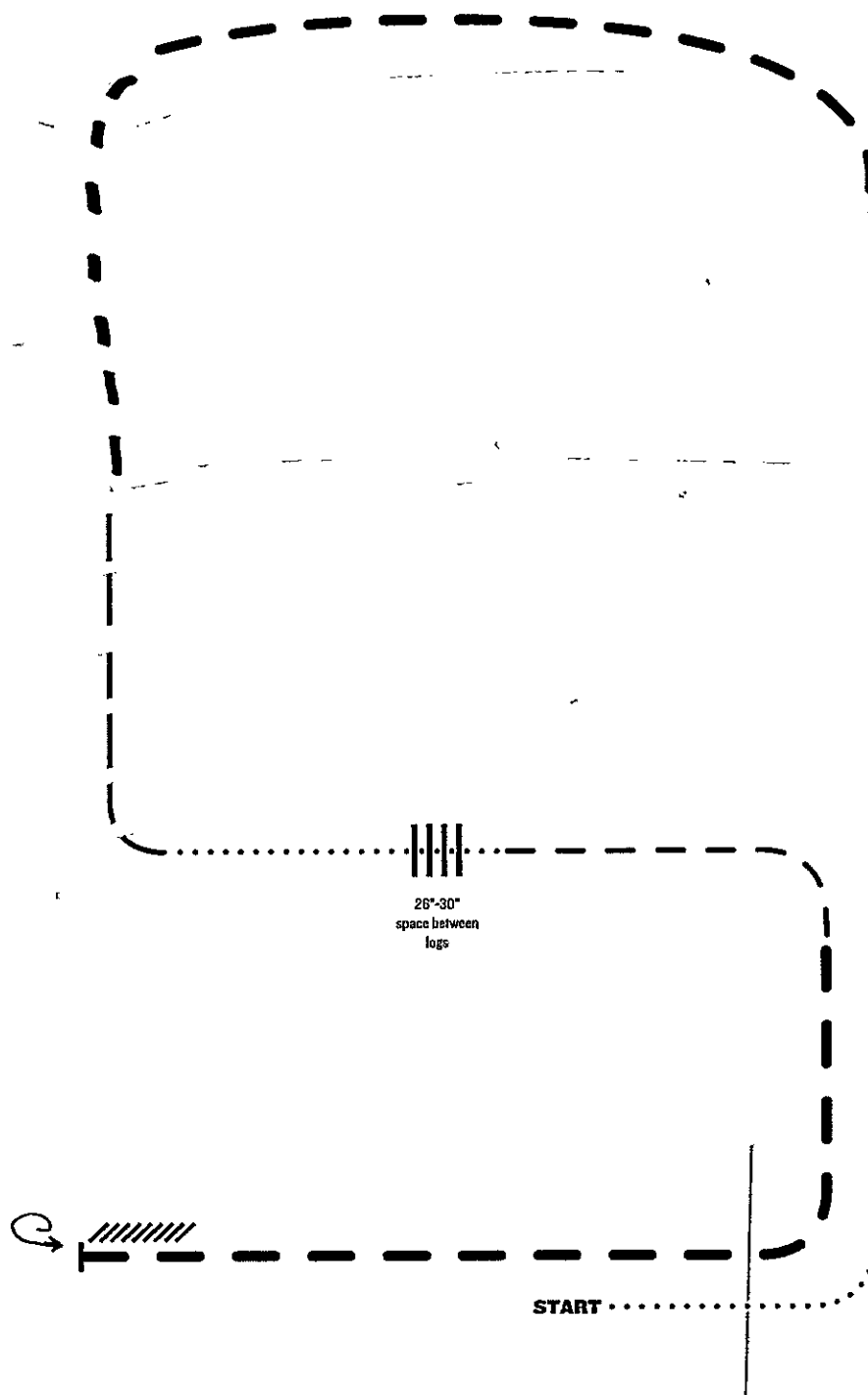

1. Walk
2. Trot
3. Extended trot
4. WALK
5. WALK LOGS
6. TROT
7. EXTENDED TROT, STOP
8. 360° TURN LEFT
9. BACK

Note: The drawn description of this pattern is only intended for the general depiction of the pattern. Exhibitors should utilize the arena space to best exhibit their horses.

Friday July 3



ENGLISH VERSATILITY

PATTERN #3

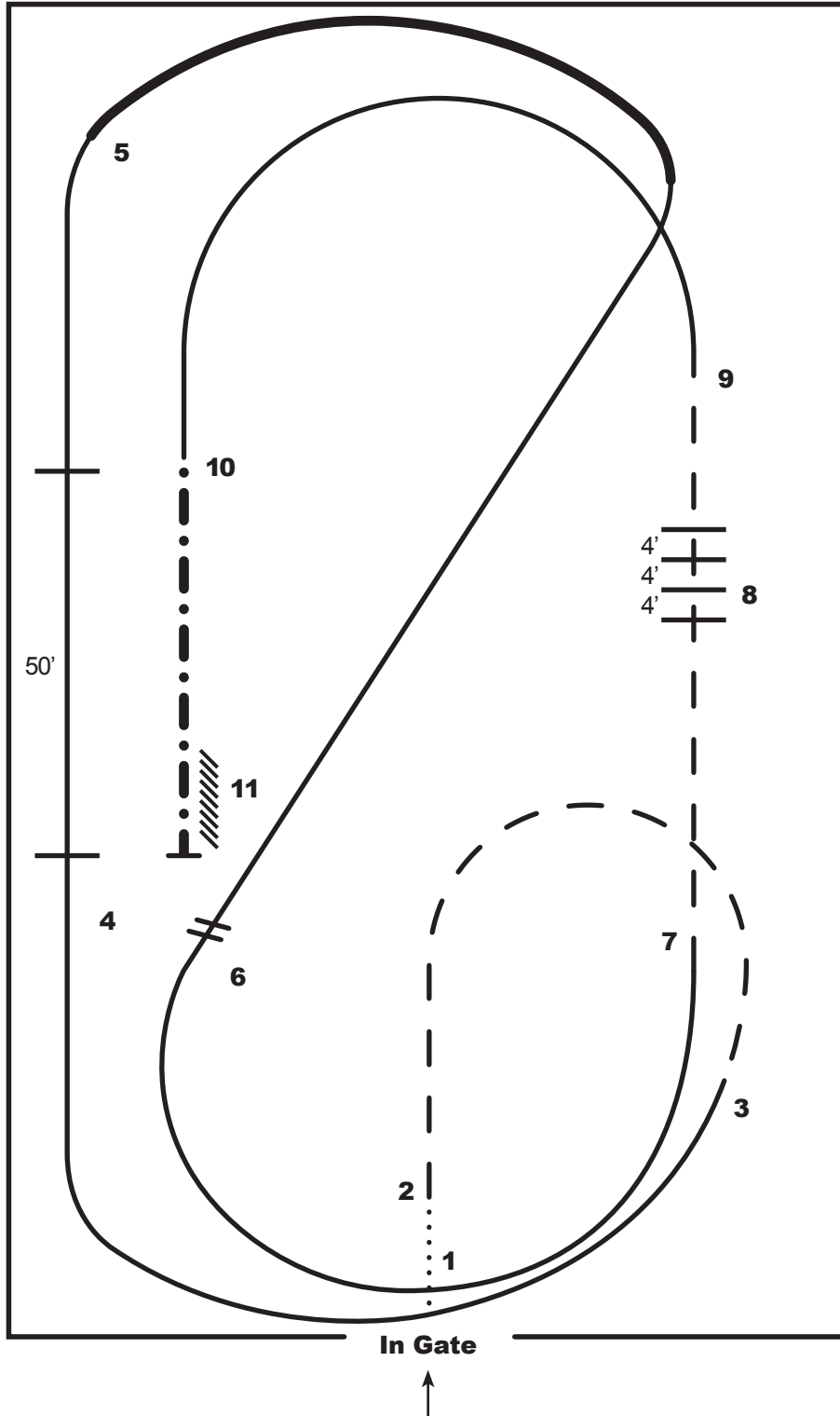

1. Forward walk from gate
2. Trot left diagonal, half circle
3. Canter right lead
4. Canter poles
5. Hand gallop through turn
6. Canter across the diagonal and change leads (simple or flying)
7. Trot right diagonal
8. Trot poles
9. Canter left lead
10. Extended sitting trot
11. Halt and back; exit ring on a loose rein

Sunday July 5



ENGLISH VERSATILITY

PATTERN #5

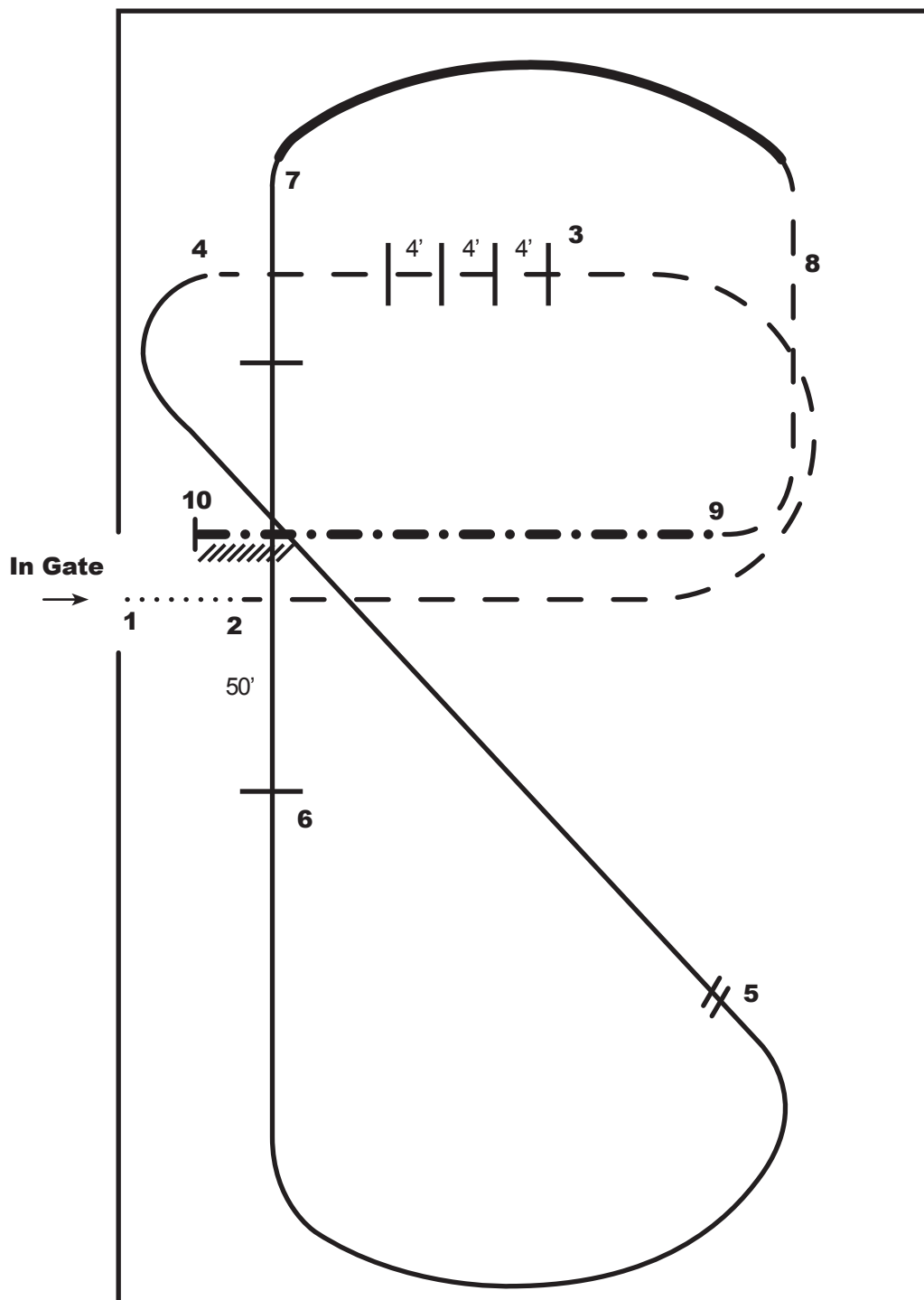

1. Forward walk from gate
2. Trot right diagonal
3. Trot poles
4. Canter left lead
5. Change leads (simple or flying)
6. Canter poles
7. Hand gallop through turn
8. Trot left diagonal
9. Extended sitting trot
10. Halt and back; exit ring on a loose rein